

EXECUTE 1110 COMPETITION TOURING CAR **XQ1**

INSTRUCTION MANUAL

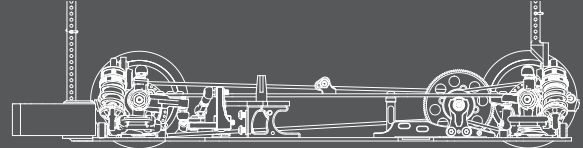

Bag A



Turnbuckle M3 x 39mm
XP-10157

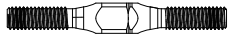

Turnbuckle M3 x 29mm
XP-10156



Turnbuckle M3 x 18mm
XP-10157

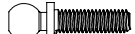

4.8mm Ball End 10mm Thread
XP-10151



4.8mm Ball End 6mm Thread
XP-10149



4.8mm Ball End 5mm Thread
XP-10148

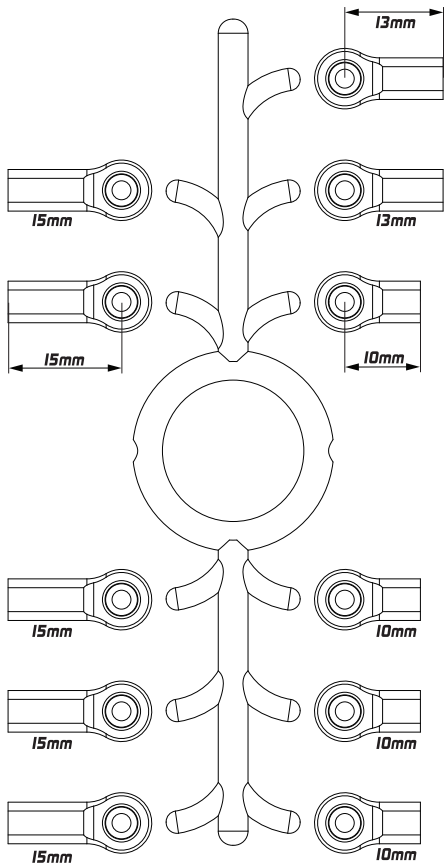

4.7mm Ball End Set
XP-10002



Alu Anti-roll Bar Bushing
XP-10152

2X

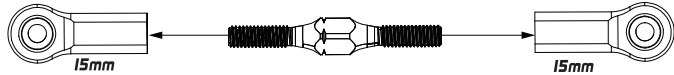

For Rear Camber Link

Turnbuckle M3 x 29mm

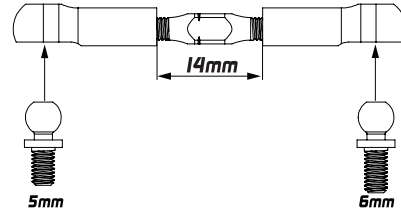

2X

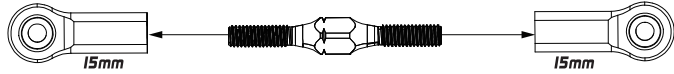

For Front Camber Link

Turnbuckle M3 x 29mm

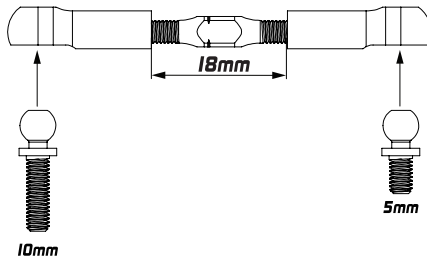

2X



For Steering

Turnbuckle M3 x 39mm

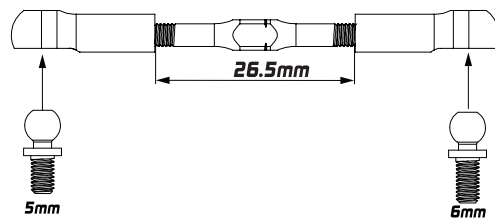

1X



For Servo

Turnbuckle M3 x 18mm

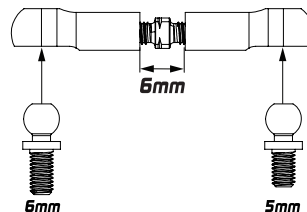

4X

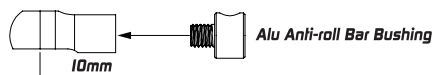

For Swaybar

Alu Anti-roll Bar Bushing



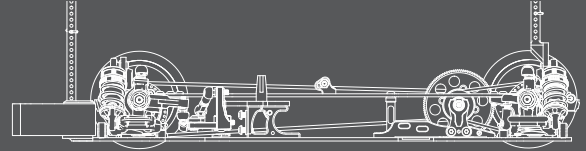

Bag B

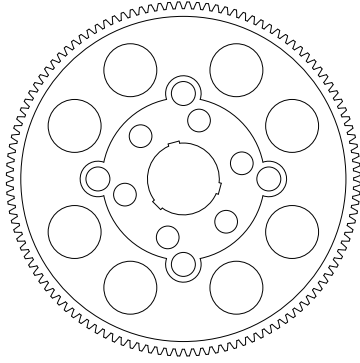

Spur Gear 64P 116T
XP-10053

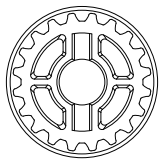

20T Center Pulley
XP-10134

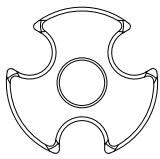

Center Pulley Cover
XP-10134

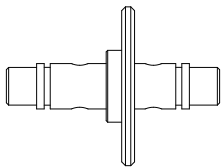

Alu Solid Layshaft
XP-10175



Set Screw M3 x 3mm
XP-40052



Button Head Screw M3 x 4mm
XP-40036

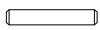

Pin 2 x 12mm
XP-40070



M5 E-Clip
XP-40058

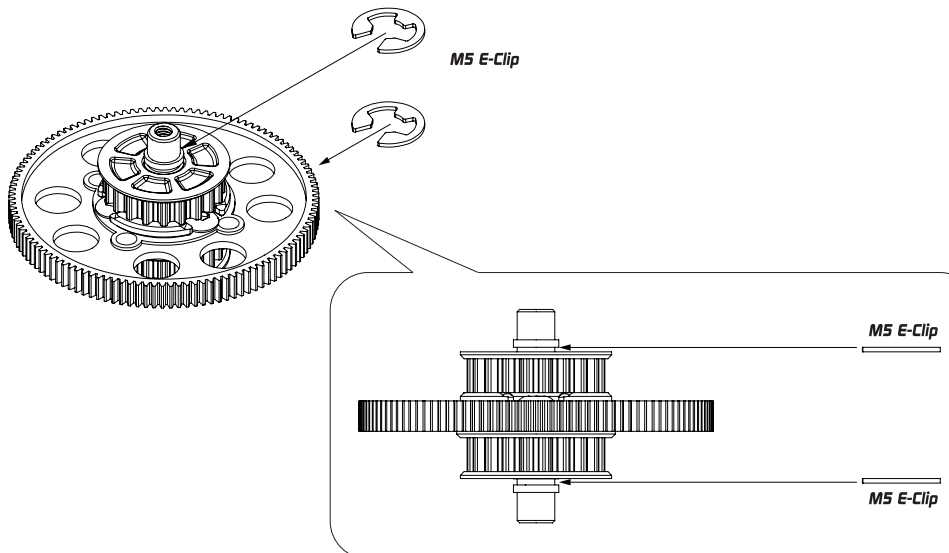
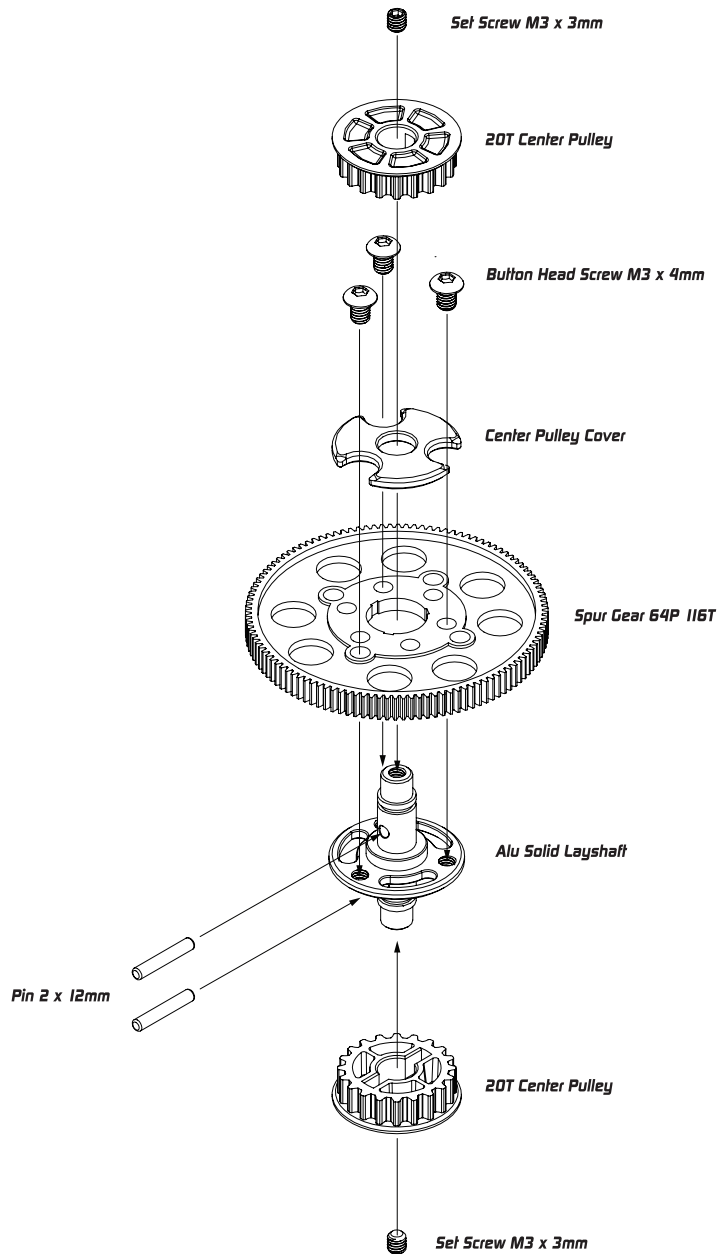

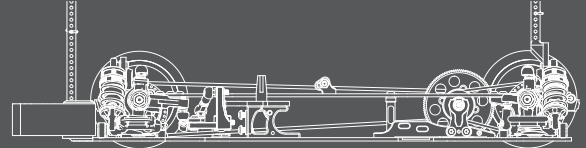

Bag C

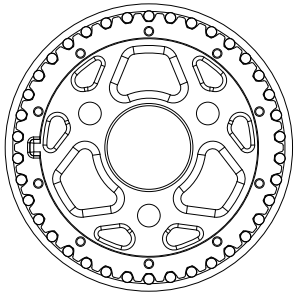

38T Pulley
XP-10134

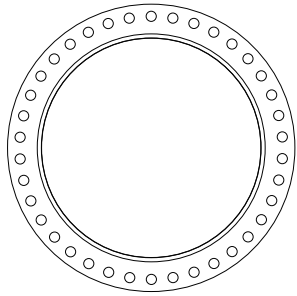

38T Pulley Cover
XP-10134

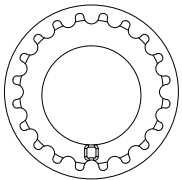

Composite Adjustment Ball-Bearing Hub
XP-10107

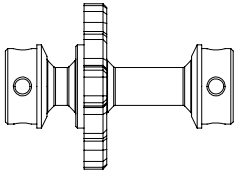

Alu Solid Spool
XP-10133

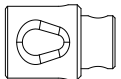

Axle Driveshaft Adapters
XP-10126



Pin 2 x 9.8mm
XP-40069

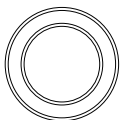

Bearing 10 x 15 x 4mm
XP-40065



Button Head Screw M3 x 6mm
XP-40037



Set Screw M3 x 3mm
XP-40052

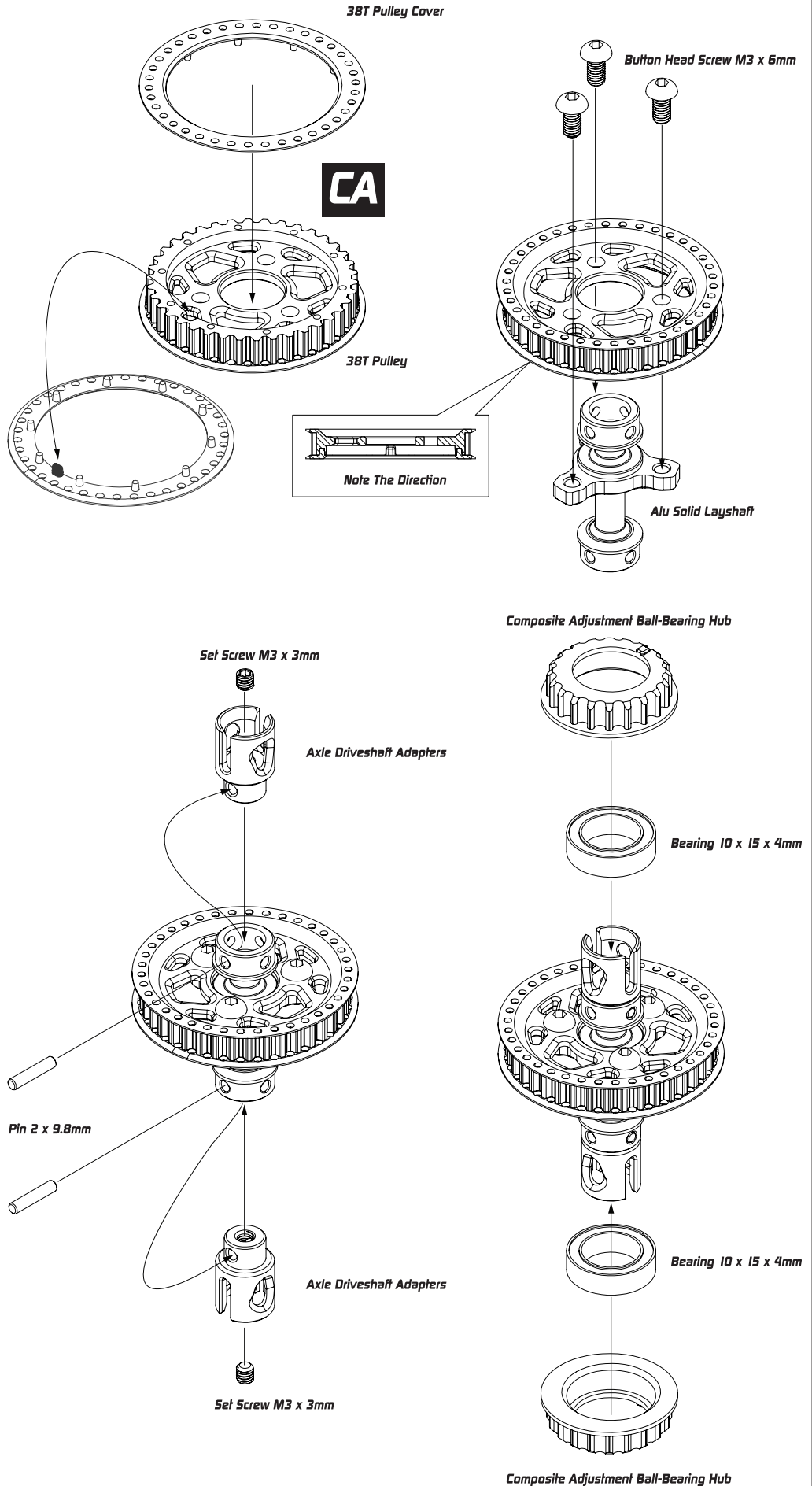

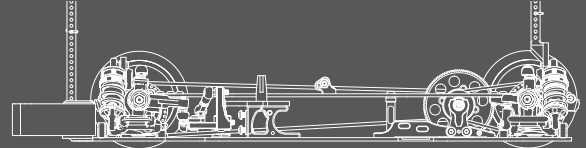

Bag D

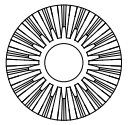

Bevel Gears 18T
XP-10009



Bevel Gears 10T
XP-10009

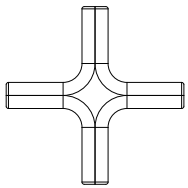

Gear Diff Cross Pin
XP-10009

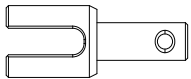

Alu Gear Diff Outdrive Adapter
XP-10125

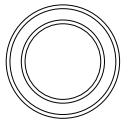

Bearing 10 x 15 x 4mm
XP-40065



O-ring 5 x 2mm
XP-10184



Pin 2 x 9.8mm
XP-40069

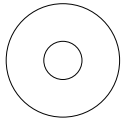

Spacer 5 x 15 x 0.4mm
XP-10181



Spacer 3.6 x 9.5 x 0.2mm
XP-10182



Flat Head Screw M2.5 x 10mm
XP-40044

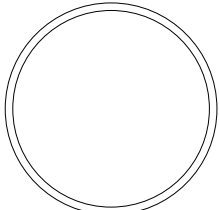

O-ring 25 x 1mm
XP-10183

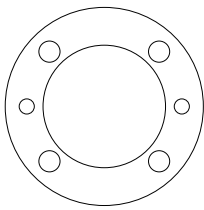

Diff Gasket
XP-10179

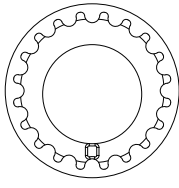

Composite Adjustment
Ball-Bearing Hub
XP-10107

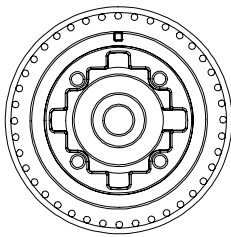

Gear Differential Case
XP-10008

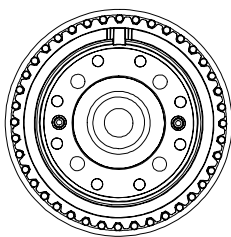

Gear Differential Cover
XP-10008

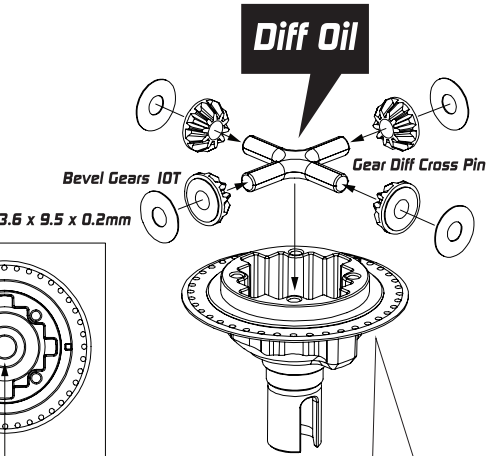
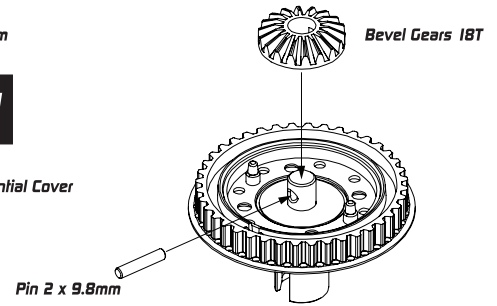
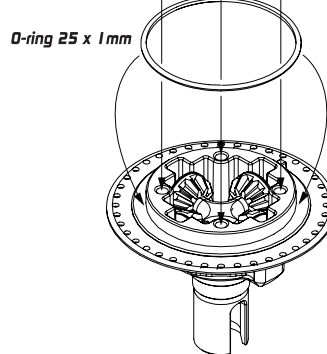
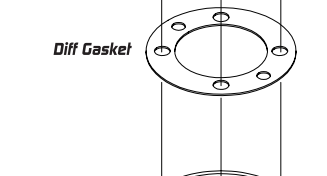
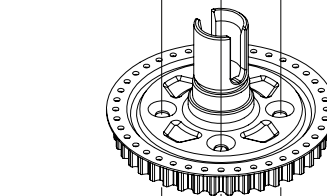
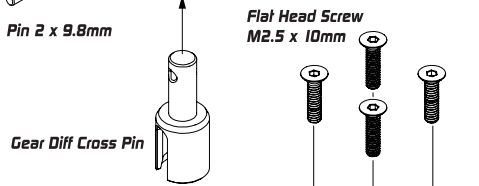
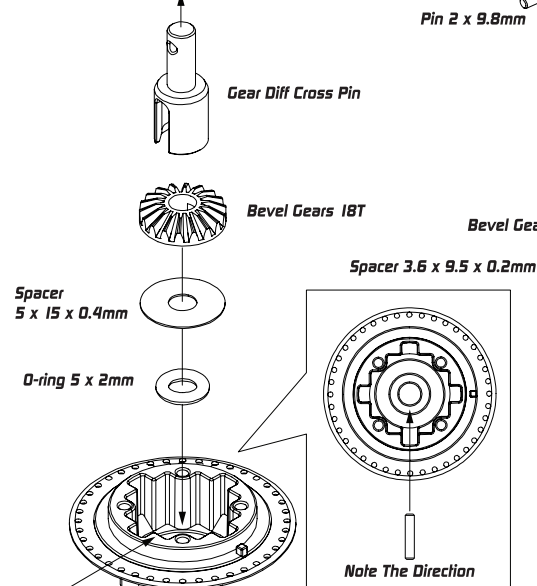
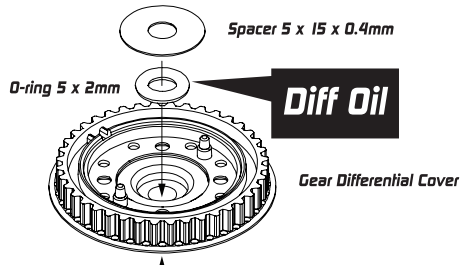

Low Grip ← High Grip
1.3g Diff Oil
3000cst ← 15000cst

Composite Adjustment Ball-Bearing Hub

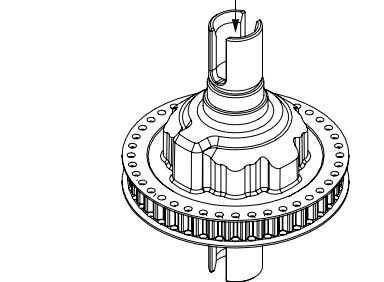
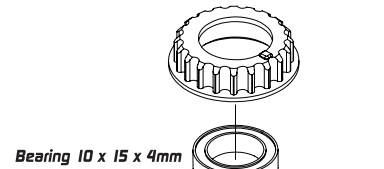

Bearing 10 x 15 x 4mm

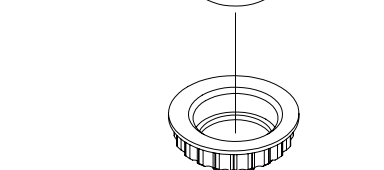

Composite Adjustment Ball-Bearing Hub

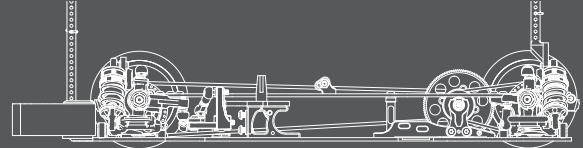

Bag E,F

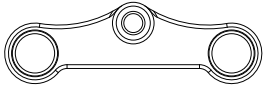

Alu Steering Plate For Dual Servo Saver 4mm
XP-10113

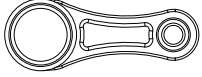

Alu Dual Servo Saver Arm
XP-10111



Bearing 5 x 8 x 2.5mm
XP-40061



Bearing 3 x 6 x 2.5mm
XP-40060



Alu Shim 3 x 6 x 1mm Red
XP-10119



Round Head Screw M3 x 8mm
XP-40038



Bulfin Head Screw M3 x 6mm
XP-40037

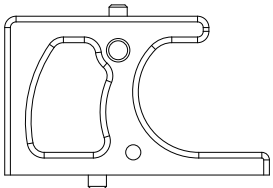

Alu Servo Mount
XP-10136

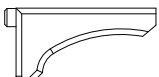

Alu Servo Side Mount
XP-10136

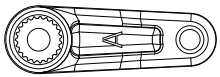

Servo Horn 23T for Sanwa, KD
XP-10163

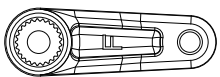

Servo Horn 25T for Fulaba
XP-10163

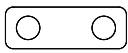

Servo Spacer
XP-10136

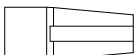

Antenna Holder
XP-10001



Flat Head Screw M3 x 10mm
XP-40049



Flat Head Screw M3 x 6mm
XP-40046



Battery Stopper
XP-10185



Graphite Floating Servo Holder 3.0mm
XP-10137

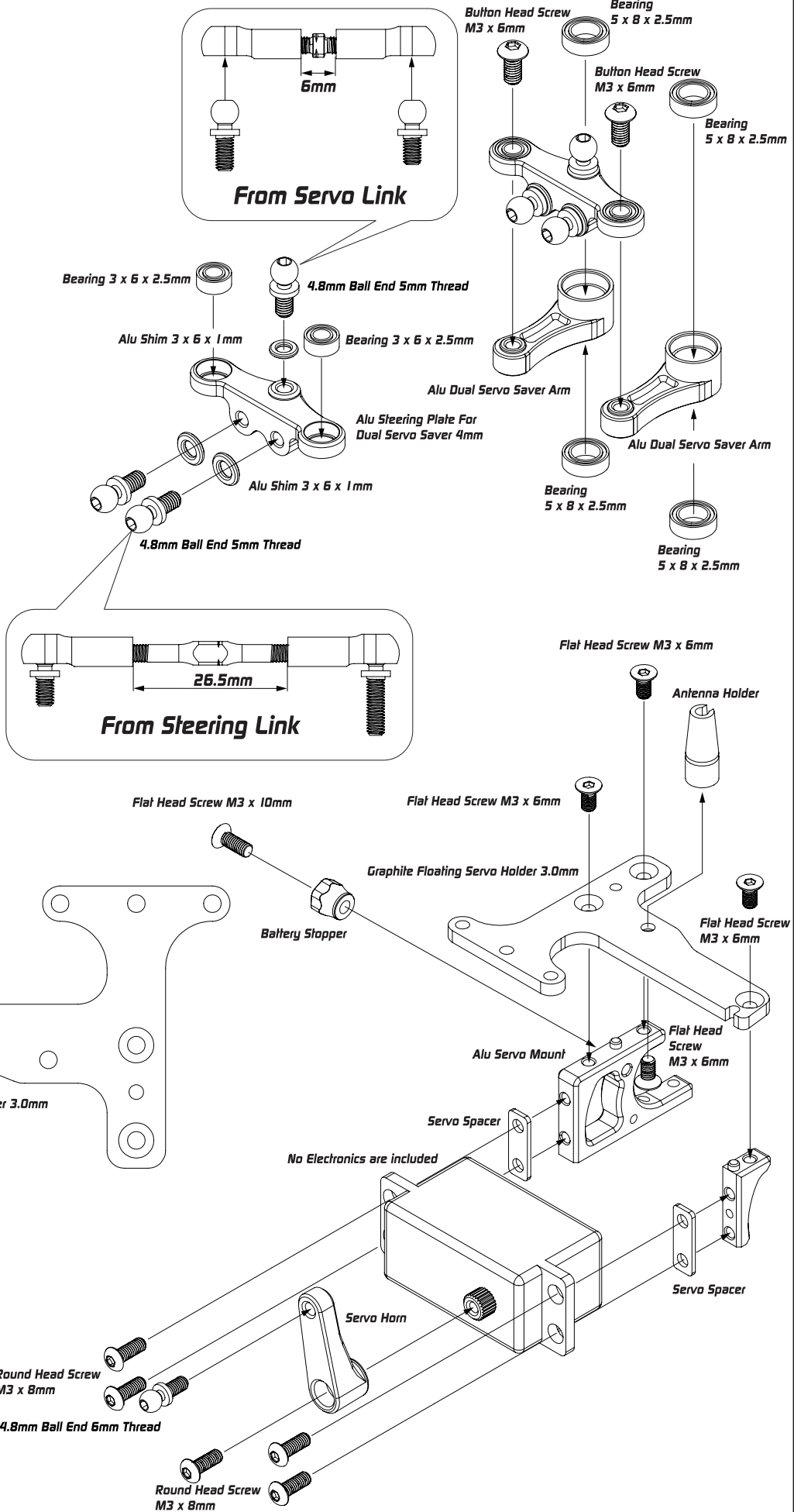

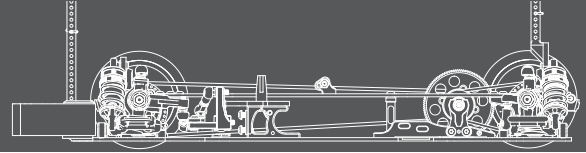

Bag G

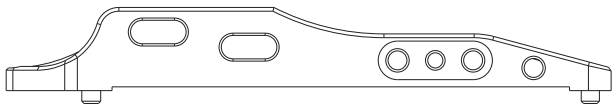

**Alu Motor Mount
XP-10117**

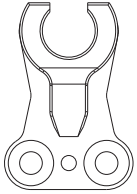

**Alu Layshaft Bulkhead
XP-10116**

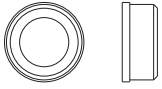

**Layshaft Bearing Holder
XP-10185**



**Bearing 5 x 9 x 3mm
XP-40062**



**Flat Head Screw M3 x 8mm
XP-40048**

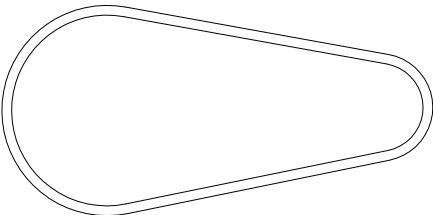

**Kevlar Drive Belt Rear 3 x 189mm
XP-10052**

**Kevlar Drive Belt Front 3 x 513mm
XP-10132**

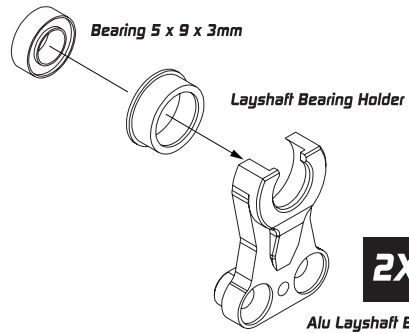

2X

Alu Layshaft Bulkhead

Flat Head Screw M3 x 8mm

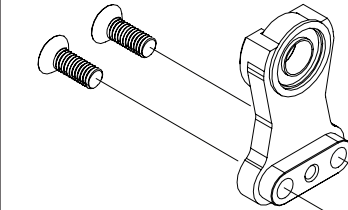

Kevlar Drive Belt Rear 3 x 189mm

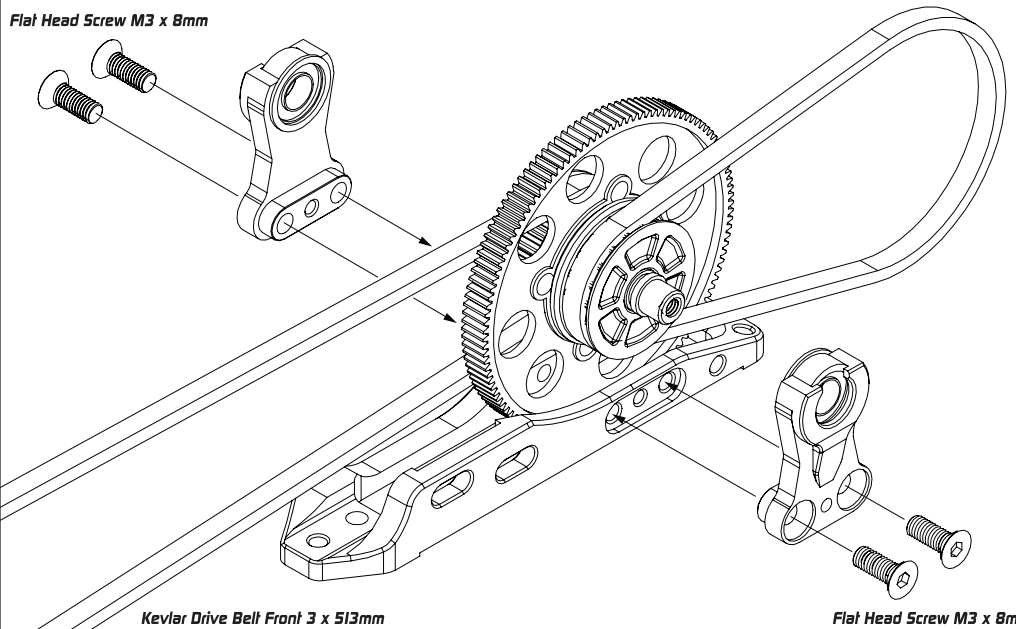

Kevlar Drive Belt Front 3 x 513mm

Flat Head Screw M3 x 8mm

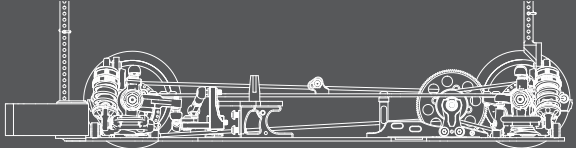

Bag H

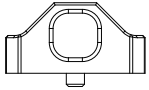

Alu Lower 2-Piece Suspension Holder
XP-10123



Flat Head Screw M3 x 6mm
XP-40046

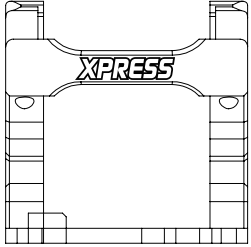

Alu Lower Bulkhead
XP-10115

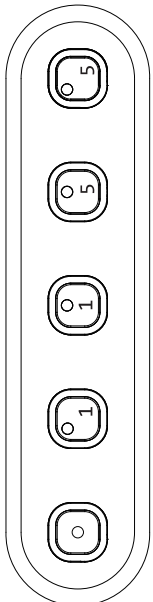
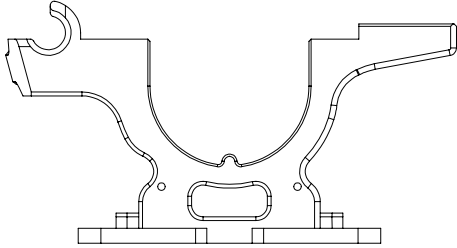

Eccentric Bushing Set
XP-10127



Default Setup

Diagonal Offset
Use either 0.5 or 1 mm to shift the roll center in a diagonal direction from the center.

4X

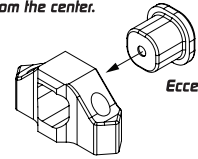

Eccentric Bushing Set

Alu Lower 2-Piece Suspension Holder

Horizontal Offset
Choice of either 0.5 or 1 mm offset from center

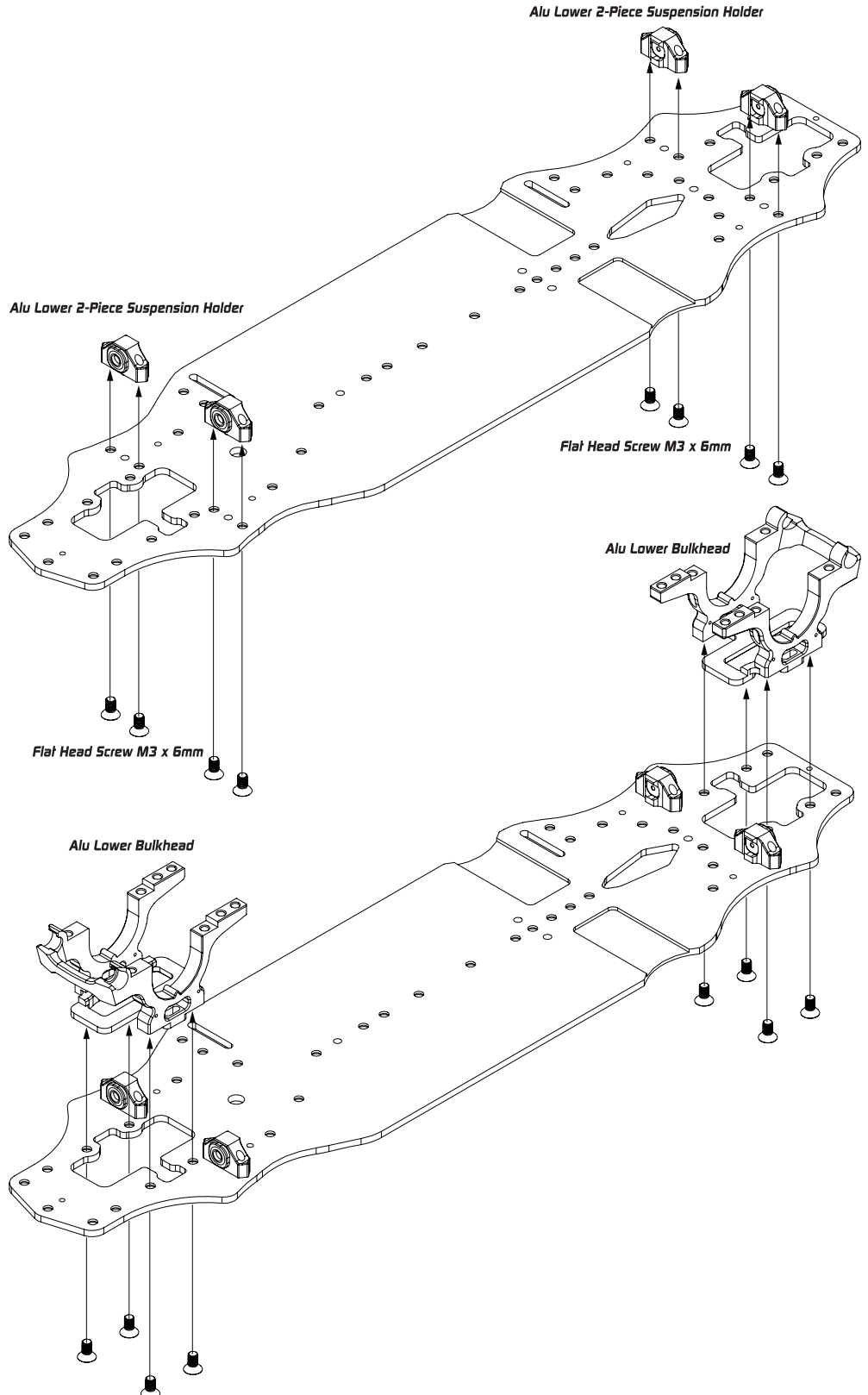

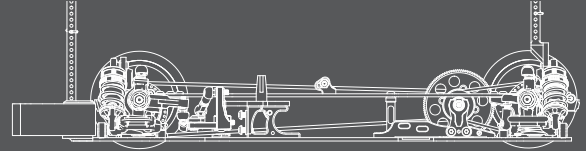

Bag 1

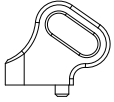

Bell Tensioner
XP-10163



Bearing 3 x 6 x 2.5mm
XP-40060



Spacer 3 x 5 x 0.2mm
XP-40066



Round Head Screw M3 x 14mm
XP-40041



Button Head Screw M3 x 6mm
XP-40037



Flat Head Screw M3 x 10mm
XP-40049



Flat Head Screw M3 x 6mm
XP-40046



Nut 3 x 5.5mm
XP-40067

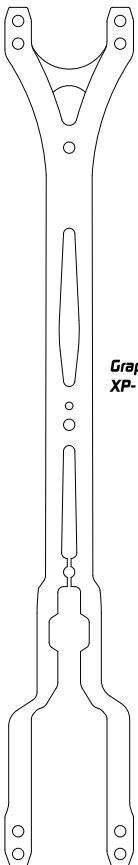

Graphite 2.0mm Upper Deck
XP-10102



Motor Mount Post
XP-10135

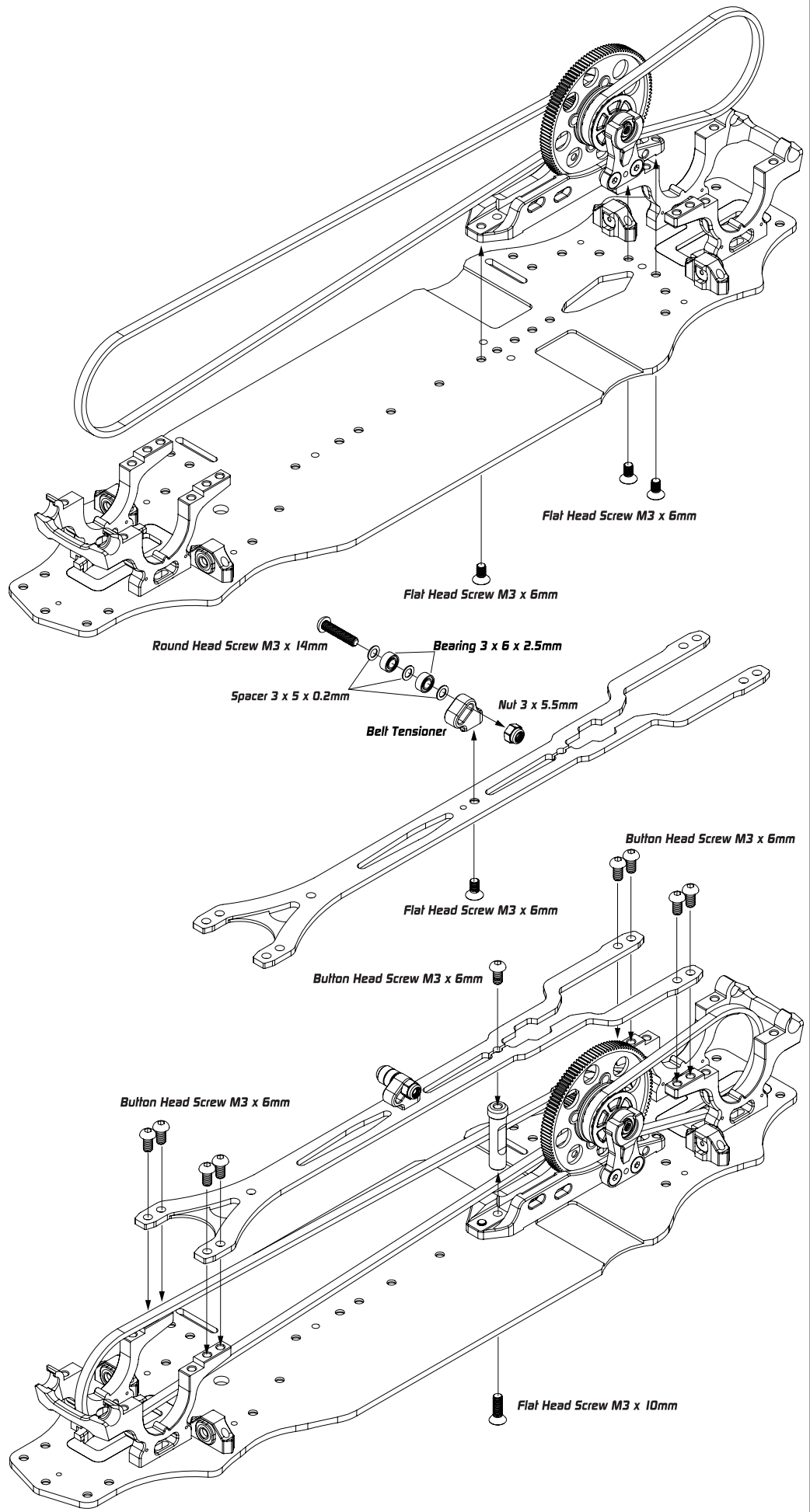

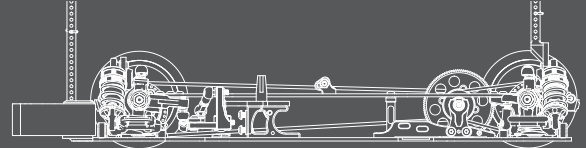

Bag J,K

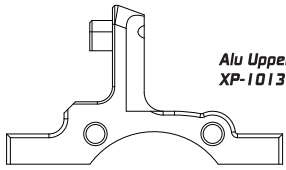

Alu Upper Clamp Rear
XP-10130

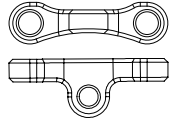

Camberlink Mount Rear
XP-10131



Round Head Screw M3 x 8mm
XP-40038

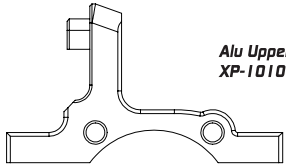

Alu Upper Clamp Front
XP-10104

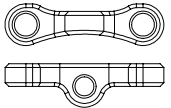

Camberlink Mount Front
XP-10105

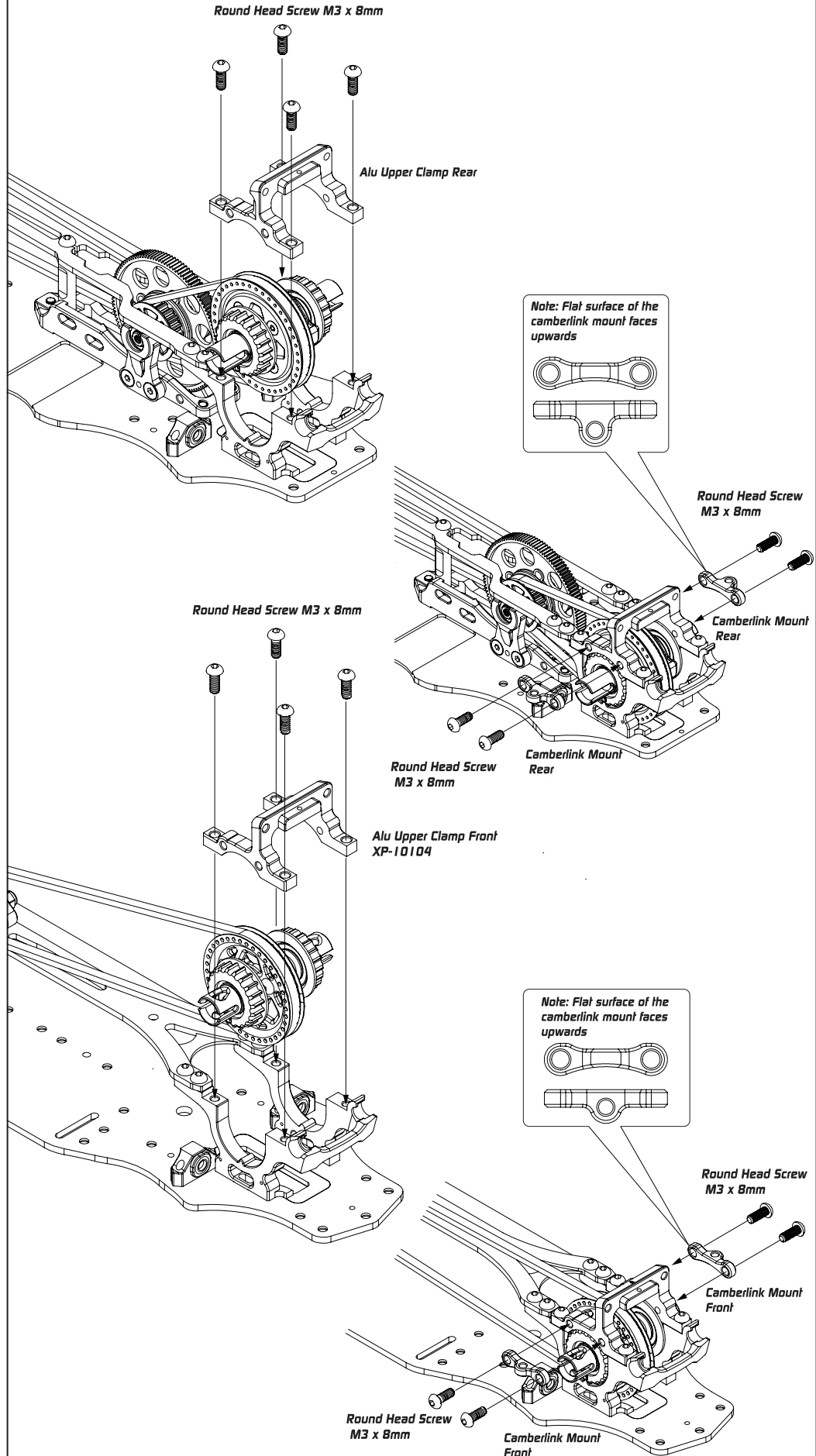

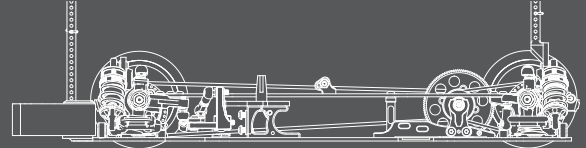

Bag E

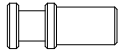

Alu Steering Post For Dual Servo Saver
XP-10112



Flat Head Screw M3 x 6mm
XP-40046



Flat Head Screw M3 x 5mm
XP-40045



Button Head Screw M3 x 6mm
XP-40037

Non-Floating Steering

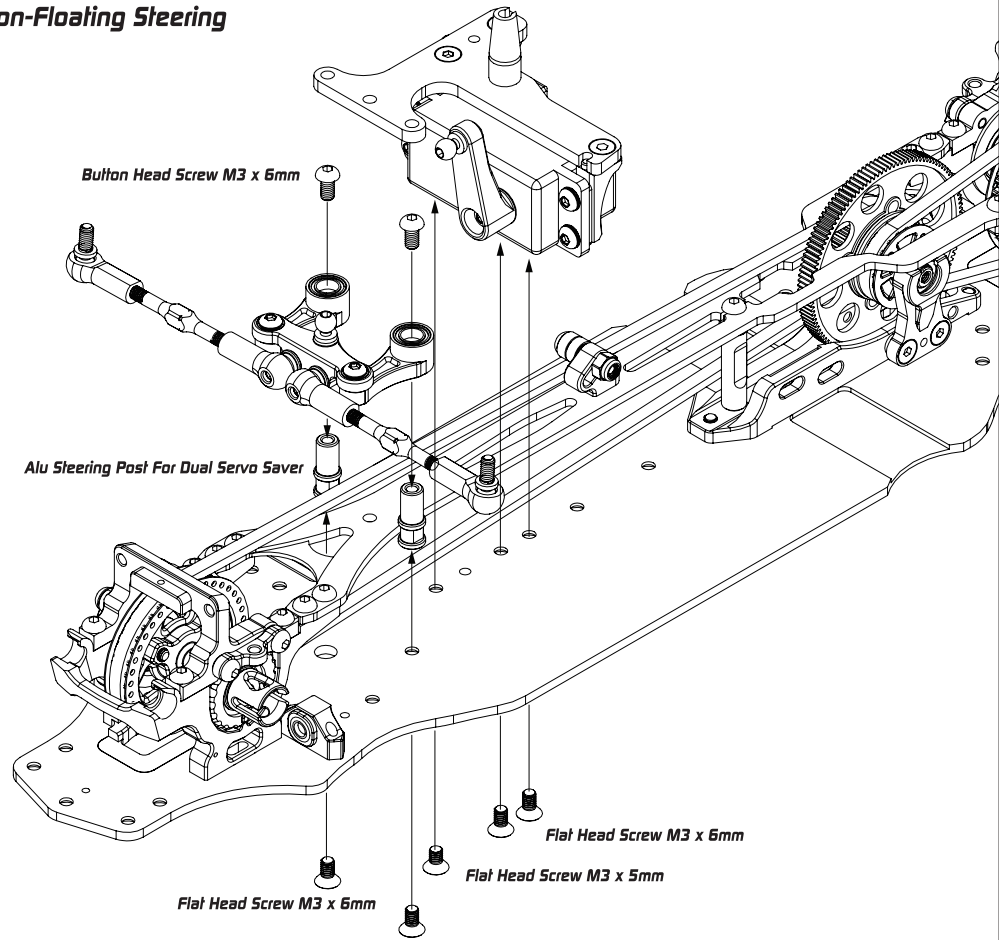

Floating Steering

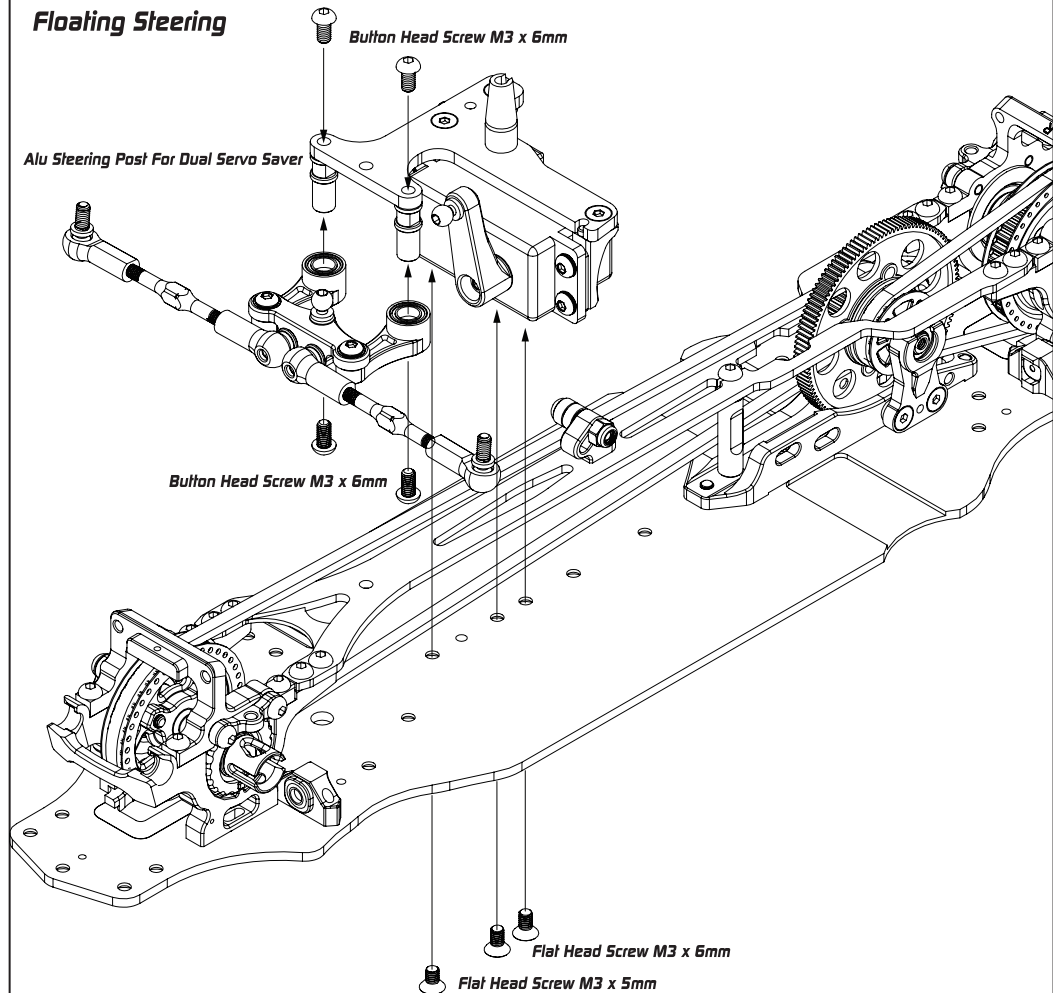

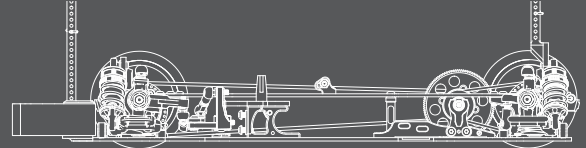

Bag L

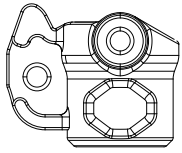

Composite Steering Block Right
XP-10109

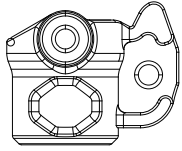

Composite Steering Block Left
XP-10109

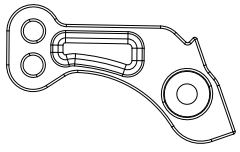

Composite Steering Block
Plate Right
XP-10109

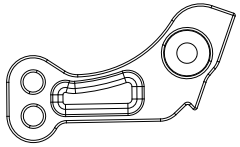

Composite Steering Block
Plate Left
XP-10109



Bearing 5 x 10 x 3mm
XP-40063



Bearing 5 x 10 x 4mm
XP-40064

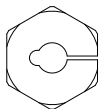

Alu Wheel Hub Red
XP-10129



Pin 2 x 9.8mm
XP-40069



Round Head Screw M3 x 8mm
XP-40038



Cap Head Screw M1.6 x 4mm
XP-10129

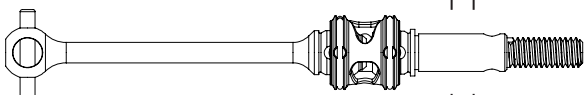

Double Joint Universal Shaft
XP-10166

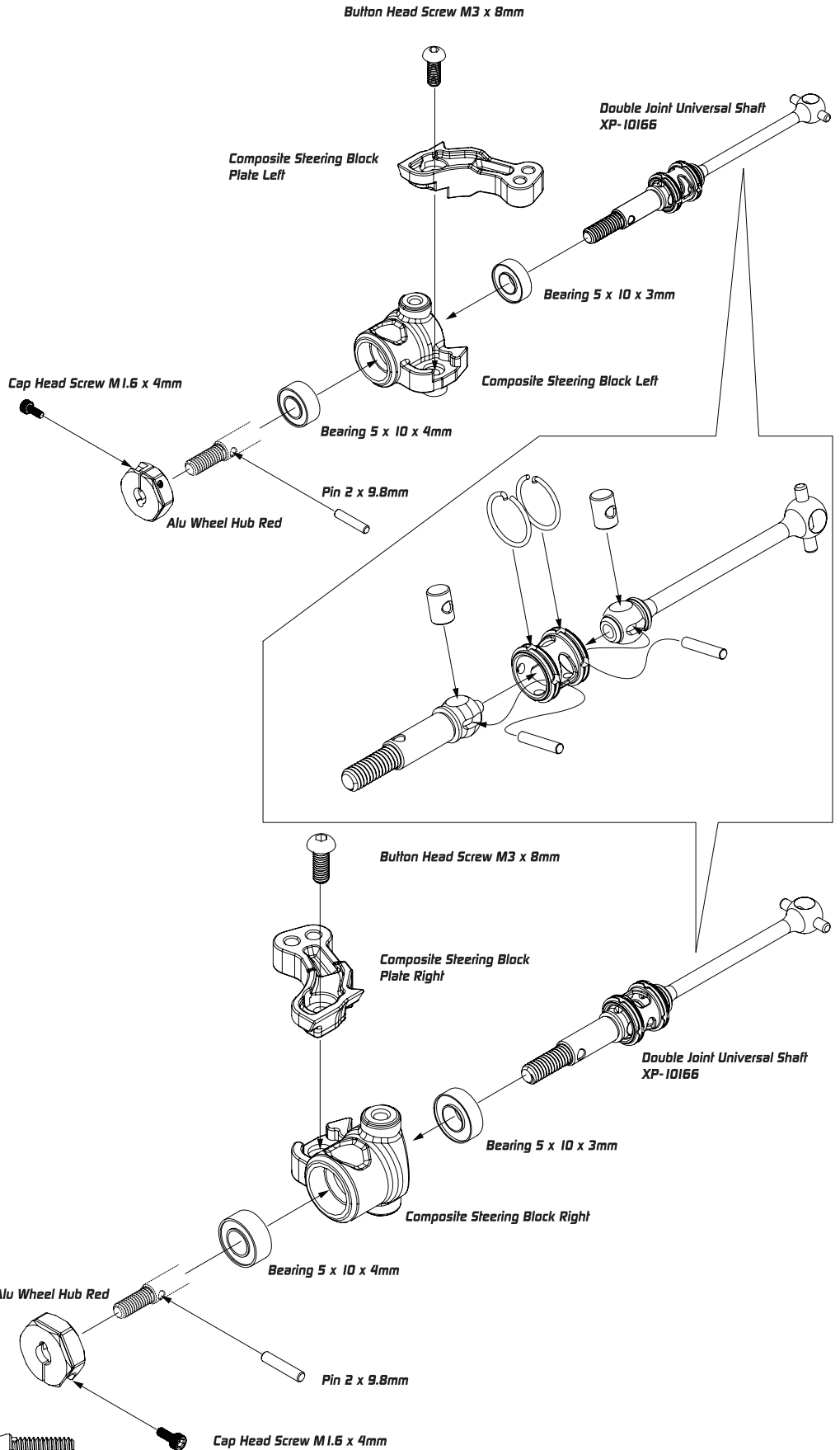

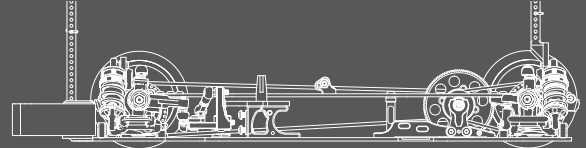

Bag M

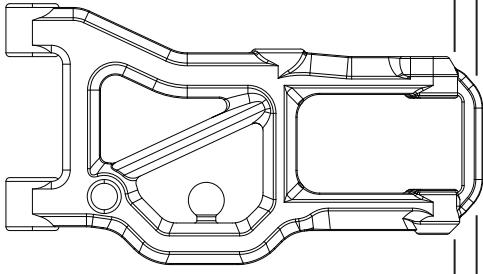

Composite Suspension Arm Front
XP-10108

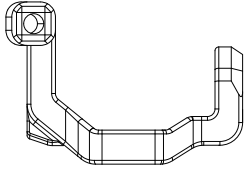

Composite C-Hub - 4° deg Left
XP-10110

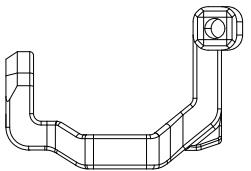

Composite C-Hub - 4° deg Right
XP-10110

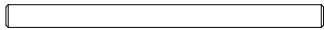

Suspension Pivot Pin 3 x 42mm
XP-10139

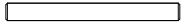

Arm Pivot Pin 2.3 x 23mm
XP-10140



Alu Shim 3 x 6 x 1mm
XP-10119



Arm Pivot Pin Screw M2 x 3.5mm
XP-10165



Hex Set Screw M4 x 10mm
XP-40056



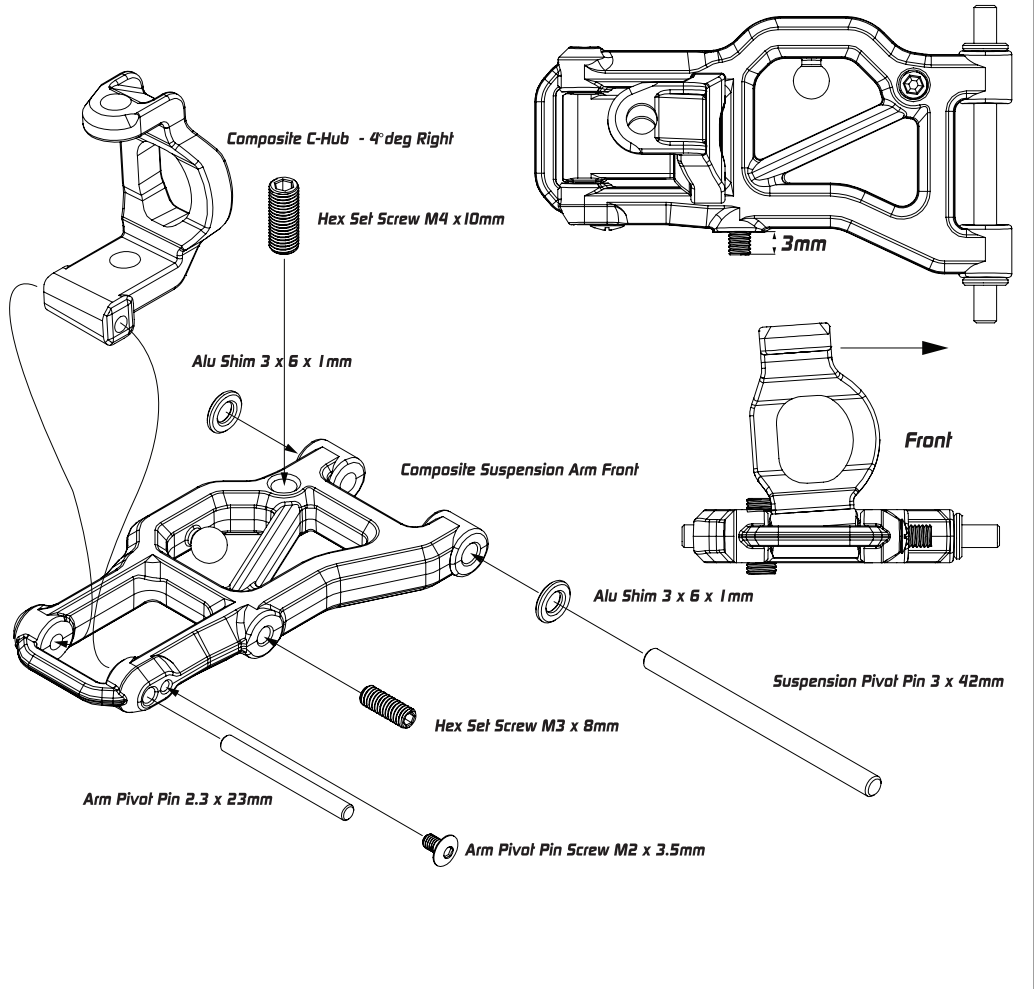
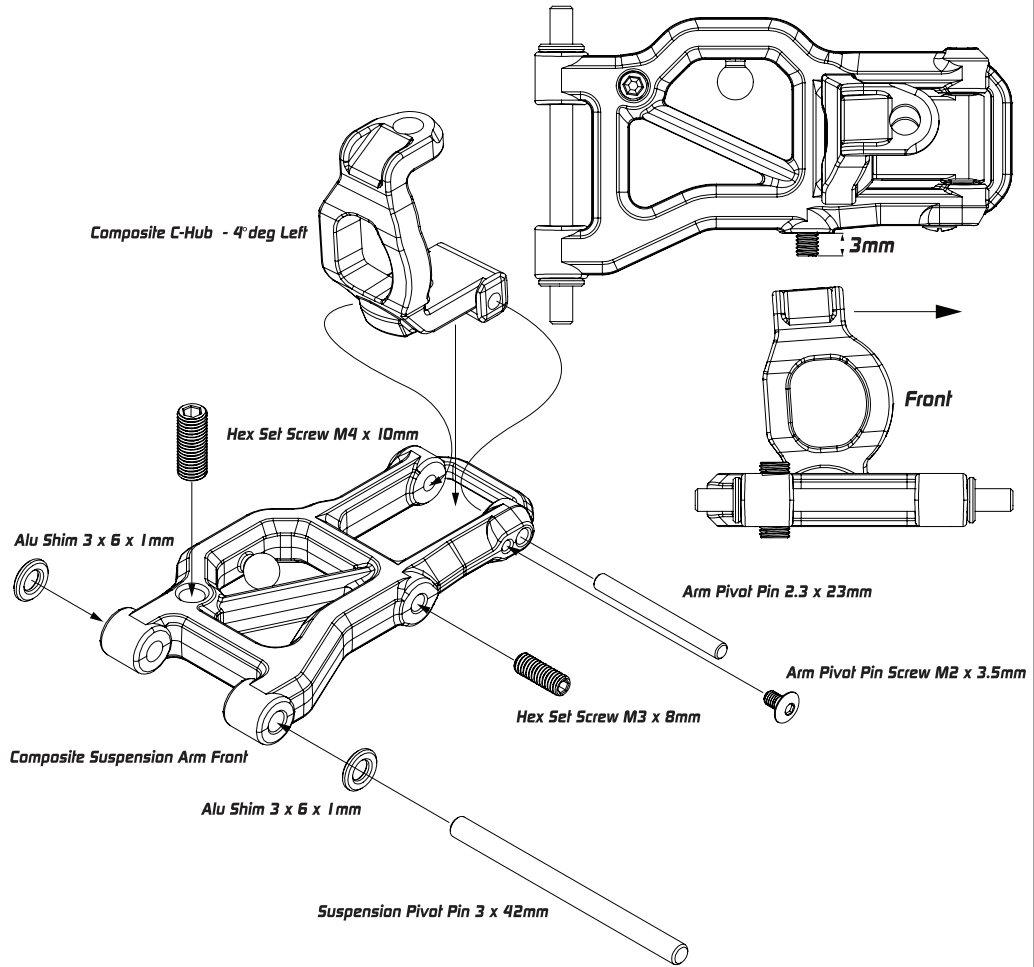

Hex Set Screw M3 x 8mm
XP-40054

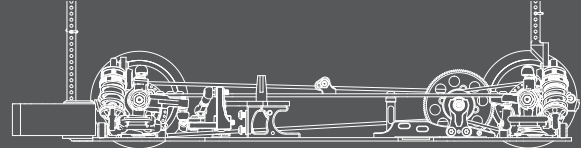



Bag M

-  **King Pin Collar**
XP-10164
-  **Alu Shim 3 x 6 x 1 mm**
XP-10119
-  **King Pin**
XP-10164

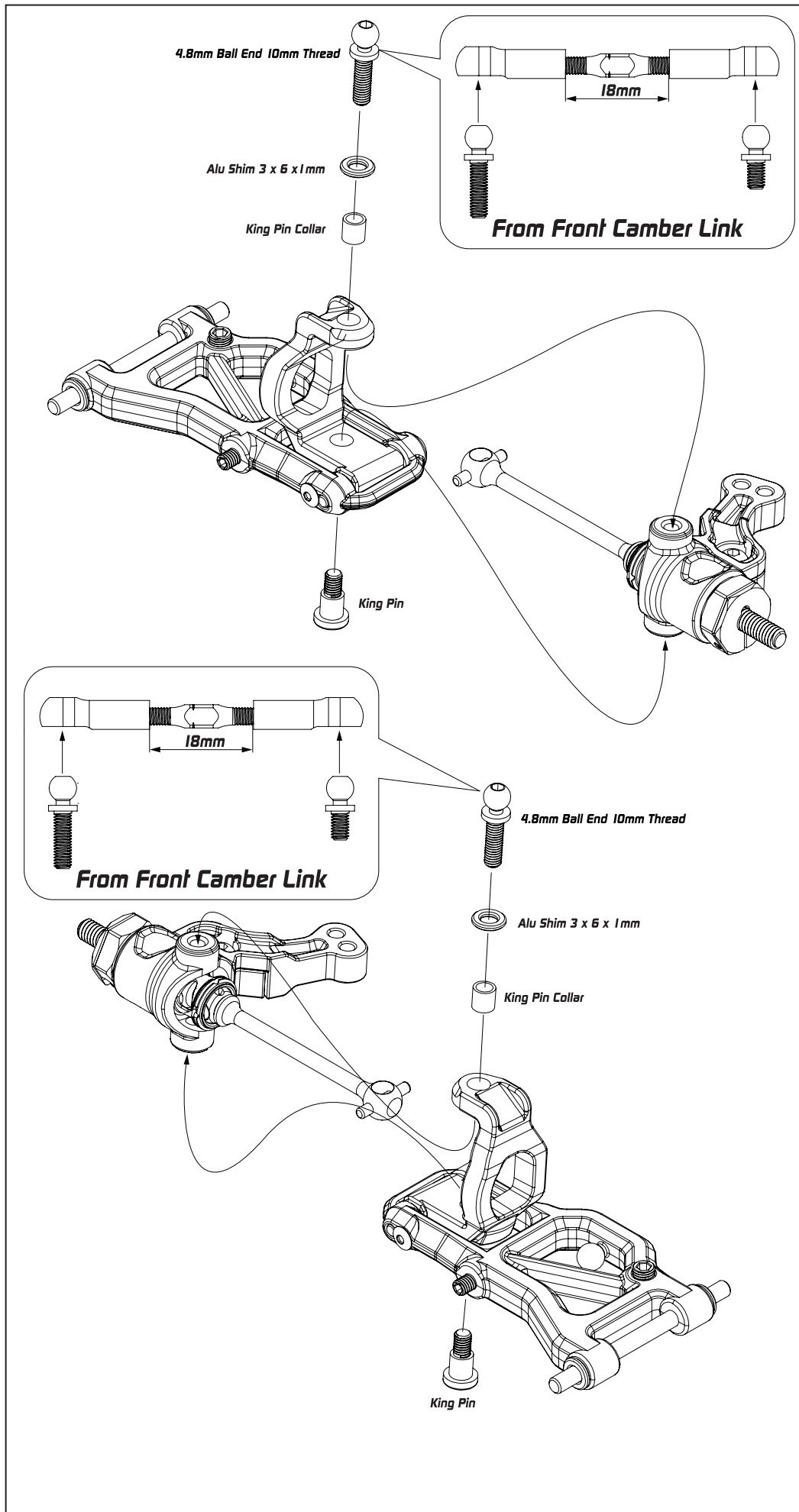

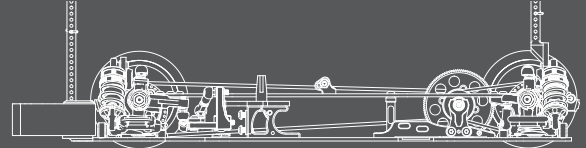

Bag M

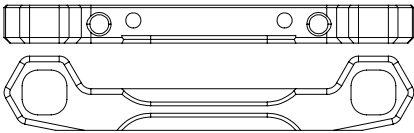

Alu Front Lower 1-Piece Suspension Holder - FF
XP-10114



Alu Shim 3 x 6 x 1 mm
XP-10119



Flat Head Screw M3 x 6mm
XP-40046

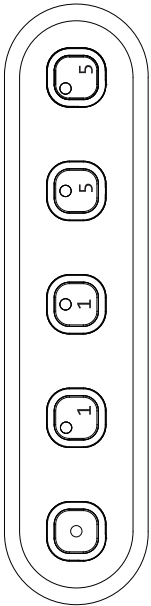

Eccentric Bushing Set
XP-10127



Diagonal Offset
Use either 0.5 or 1 mm to shift the roll center in a diagonal direction from the center.

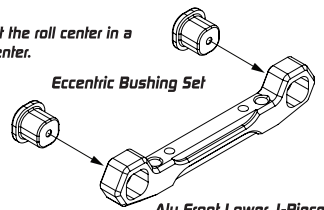

Eccentric Bushing Set

Alu Front Lower 1-Piece Suspension Holder - FF



Horizontal Offset
Choice of either 0.5 or 1 mm offset from center

Default Setup

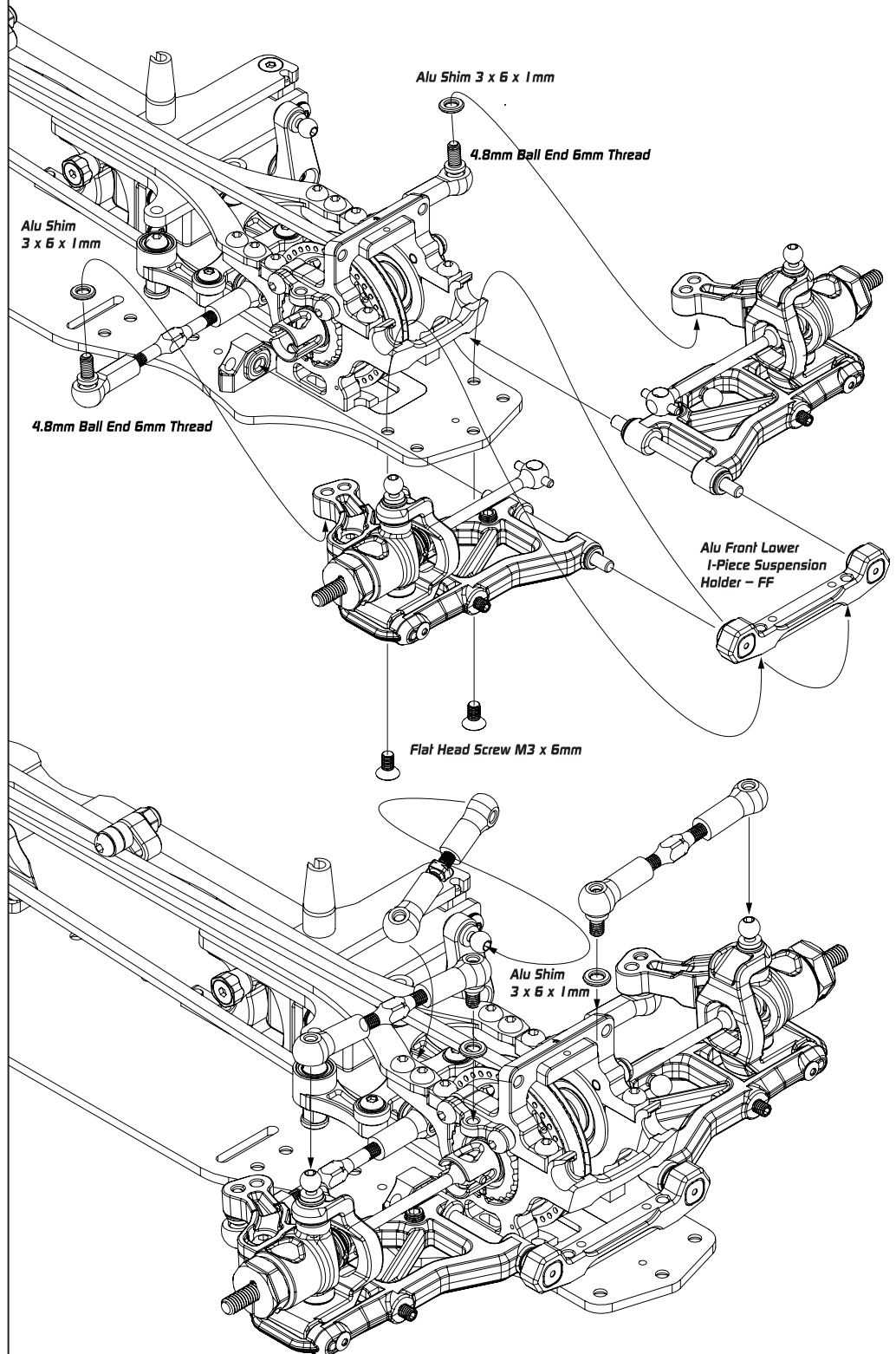

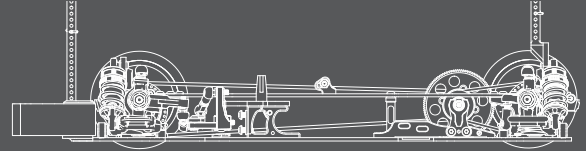

Bag N,0

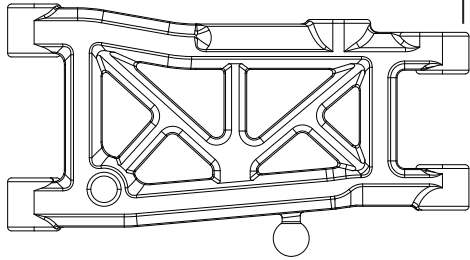

Composite Suspension Arm Rear
XP-10108

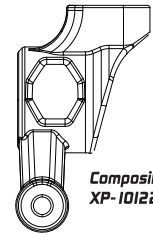

Composite Rear Upright
XP-10122

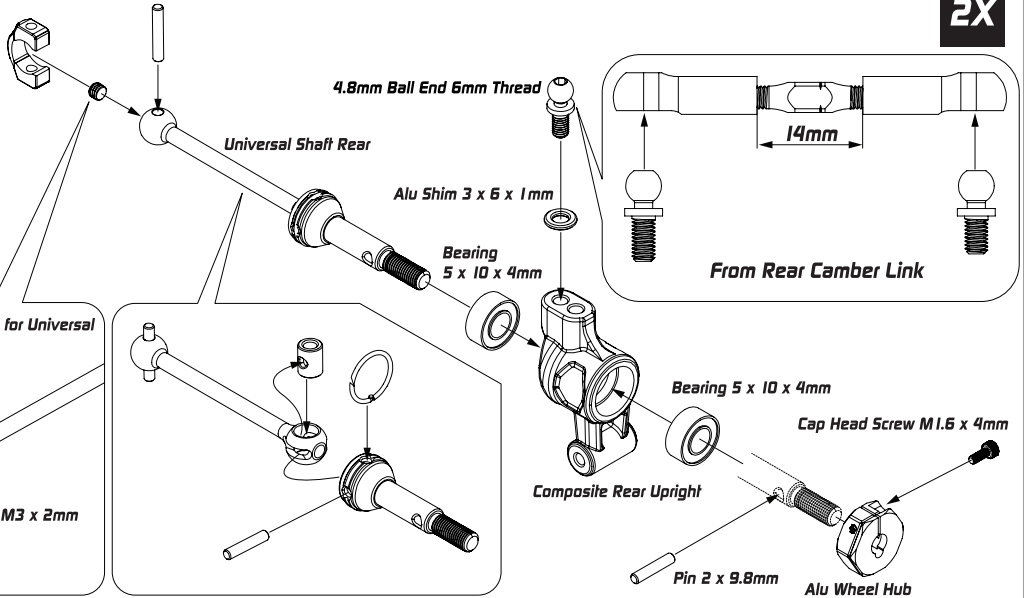

Steel 2 x 12mm Flatspot Pin for Universal

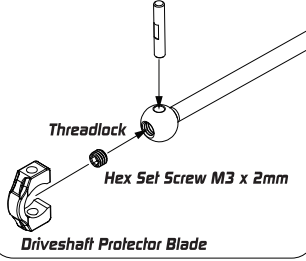

Driveshaft Protector Blade
XP-10128



Bearing 5 x 10 x 4mm
XP-40064



Alu Wheel Hub
XP-10129



Pin 2 x 9.8mm
XP-40069



Alu Shim 3 x 6 x 1mm
XP-10119



Suspension Pivot Pin 3 x 42mm
XP-10139

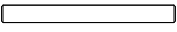

Arm Pivot Pin 2.3 x 23mm
XP-10140



Steel 2 x 12mm Flatspot Pin for Universal
XP-40071



Cap Head Screw M1.6 x 4mm
XP-10129



Arm Pivot Pin Screw M2 x 3.5mm
XP-10165



Hex Set Screw M4 x 10mm
XP-40056



Hex Set Screw M3 x 8mm
XP-40054

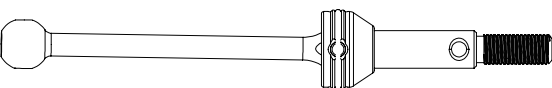

Universal Shaft Rear
XP-10167

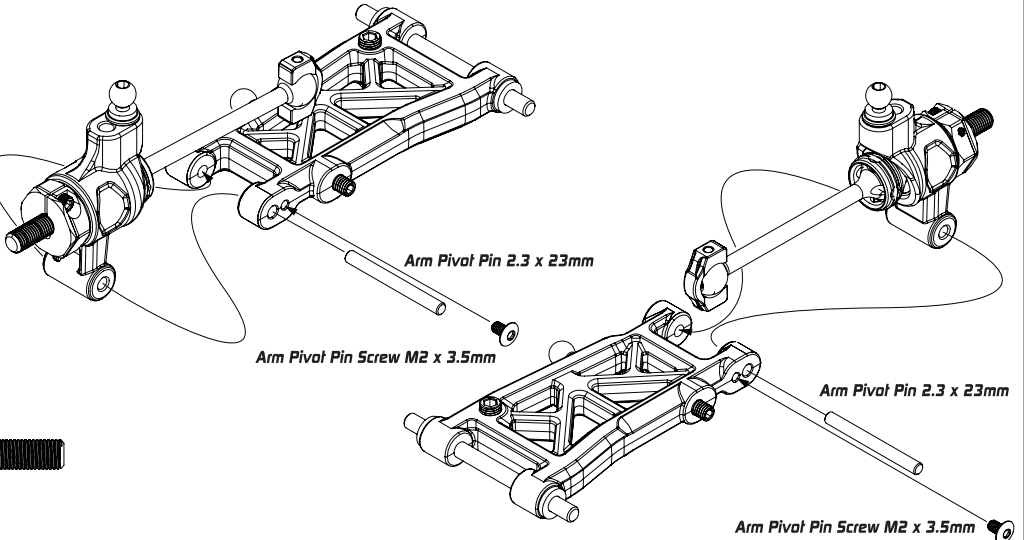
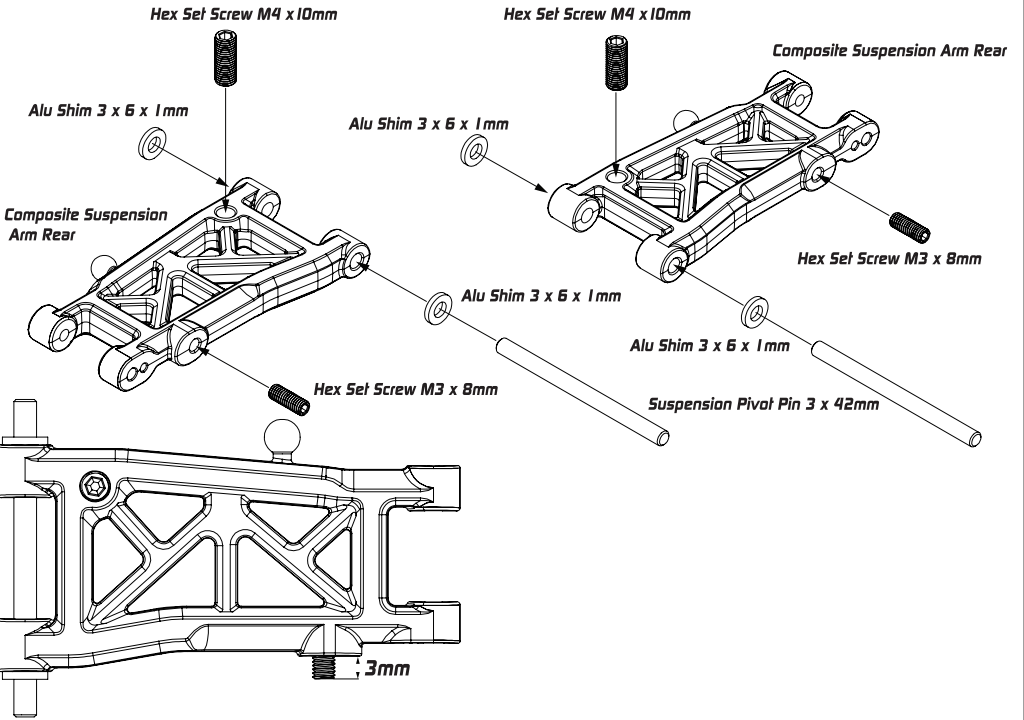

EXECUTE XQ1 16. Rear End Assembly

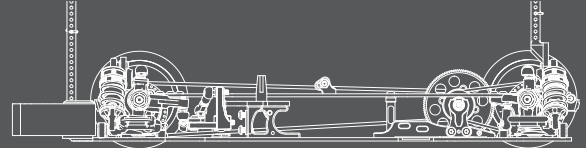

Bag 0

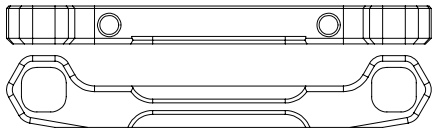

Alu Rear Lower 1-Piece Suspension holder - RR
XP-10124



Flat Head Screw M3 x 6mm
XP-40046

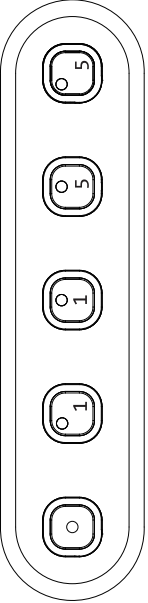

Eccentric Bushing Set
XP-10127



Alu Shim 3 x 6 x 1 mm
XP-10119



Diagonal Offset
Use either 0.5 or 1 mm to shift the roll center in a diagonal direction from the center.



Default Setup

Alu Rear Lower 1-Piece Suspension holder - RR

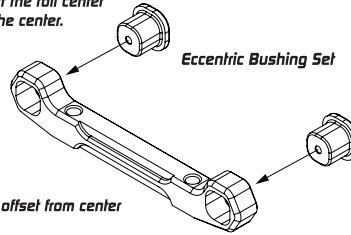

Eccentric Bushing Set

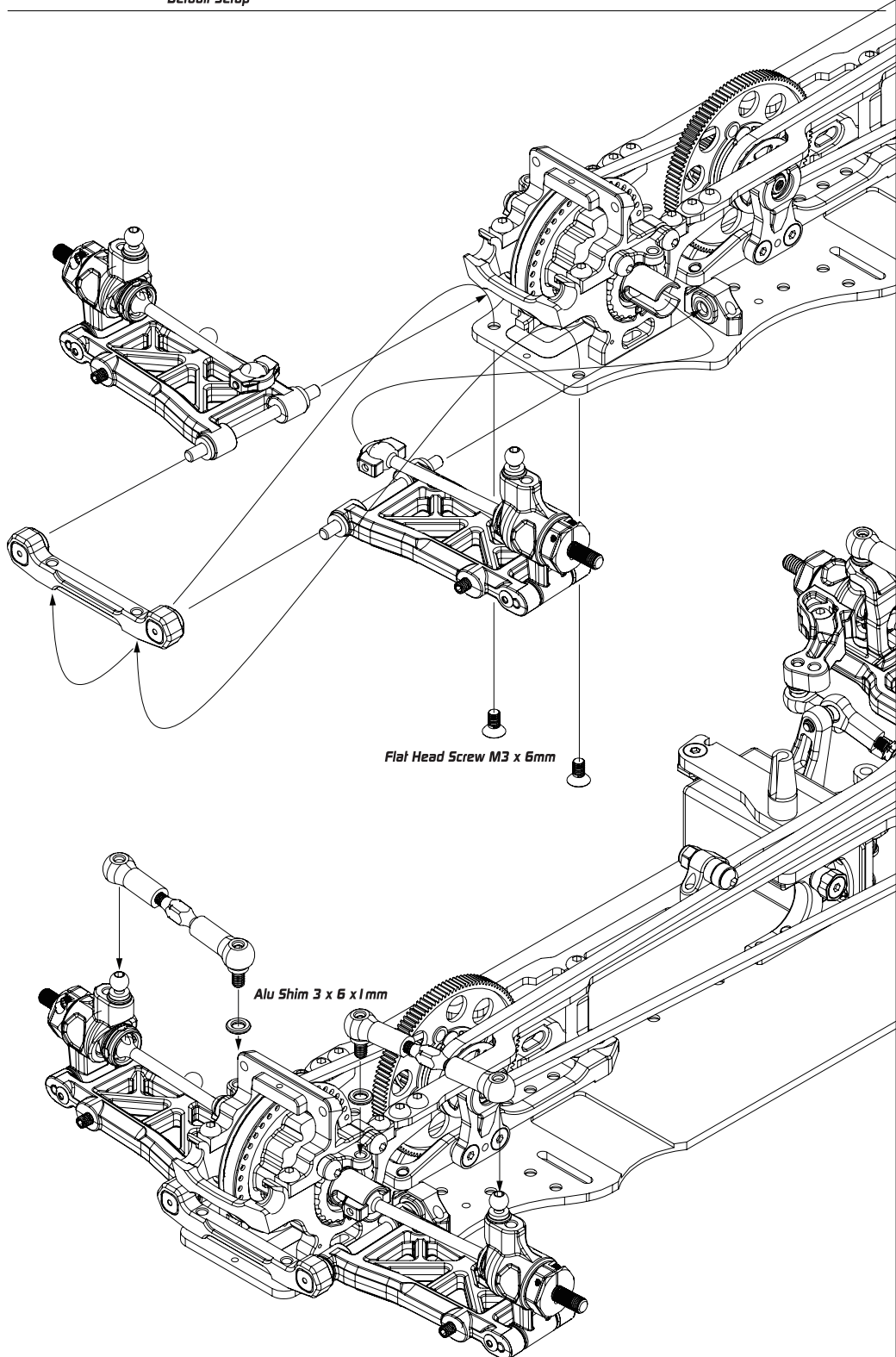

Flat Head Screw M3 x 6mm

Alu Shim 3 x 6 x 1 mm

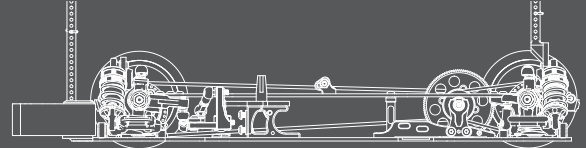

Bag P

Front

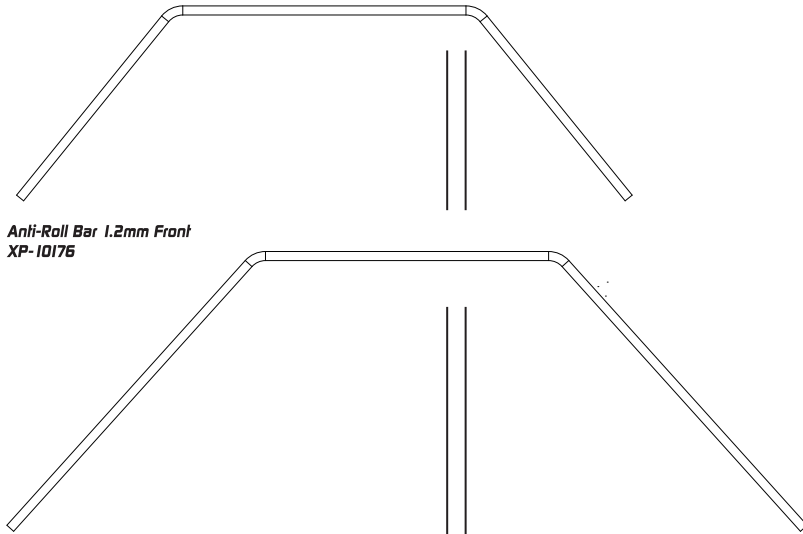

Anti-Roll Bar 1.2mm Front
XP-10176

Anti-Roll Bar 1.2mm Rear
XP-10176

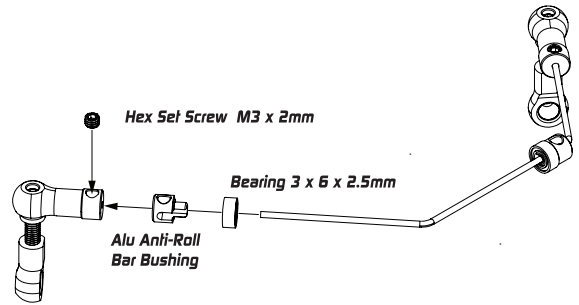

Hex Set Screw M3 x 2mm

Bearing 3 x 6 x 2.5mm

Alu Anti-Roll
Bar Bushing

Rear

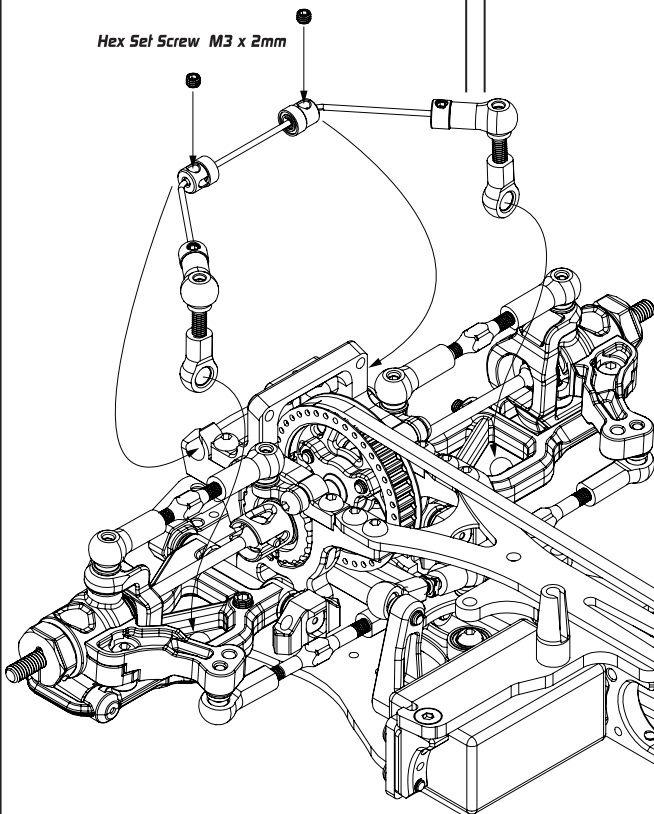

Hex Set Screw M3 x 2mm

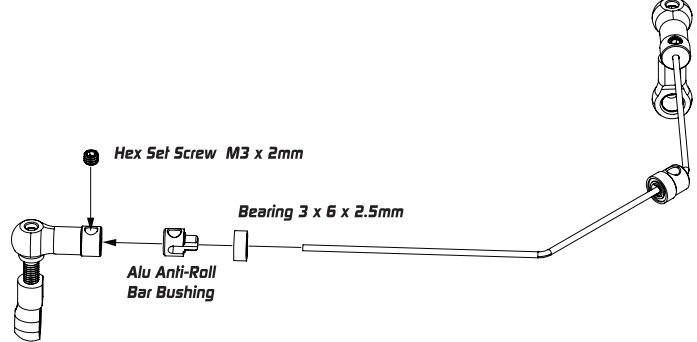

Hex Set Screw M3 x 2mm

Bearing 3 x 6 x 2.5mm

Alu Anti-Roll
Bar Bushing

Hex Set Screw M3 x 2mm



Bearing 3 x 6 x 2.5mm
XP-40060



Alu Anti-Roll Bar Bushing
XP-10152



Hex Set Screw
M3 x 2mm
XP-40051

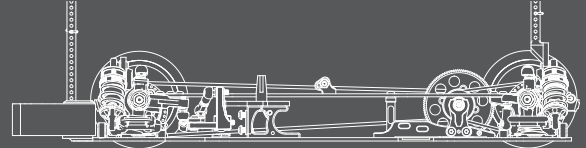

Bag Q

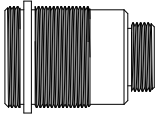

Alu Shock Body
XP-10142

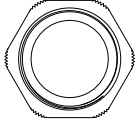

Alu Upper Shock Cap
XP-10146

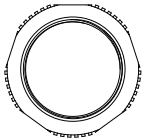

Alu Spring Tension Adjust Nut
XP-10161



Alu Lower Shock Cap
XP-10145

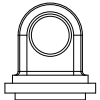

Shock Top Connector v



4 Hole Piston
XP-10159

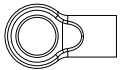

Shock Lower Connector
XP-10144



Shaft Cover
XP-10159



Shaft Spacer
XP-10159

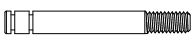

Shock Shaft
XP-10143



Shock Absorber Membrane
XP-10147

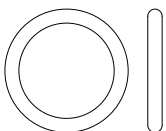

Silicone O Ring For Spring Adjust Nut
XP-10162



Shock O-Ring
XP-10160



E-Clip 2.5mm
XP-40057

Silicone O Ring For Spring Adjust Nut



Alu Spring Tension Adjust Nut

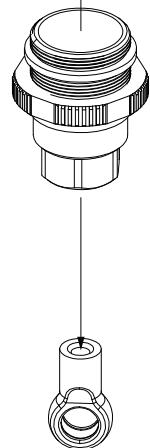
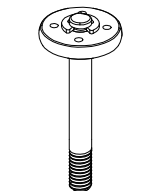
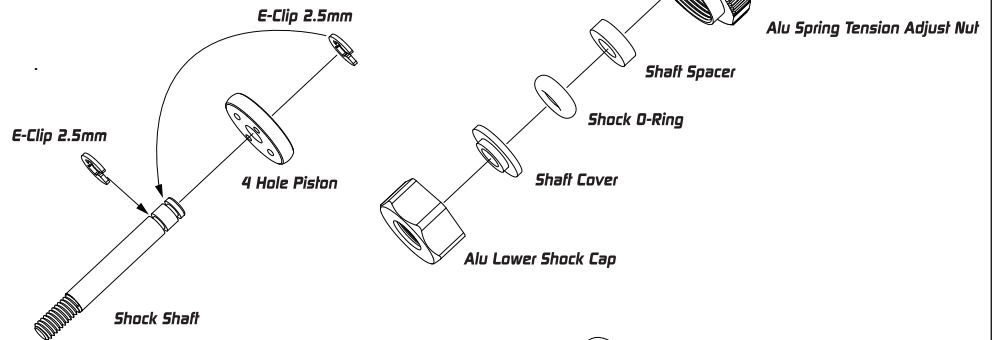

Shock Lower Connector

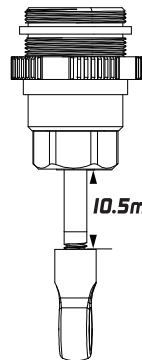
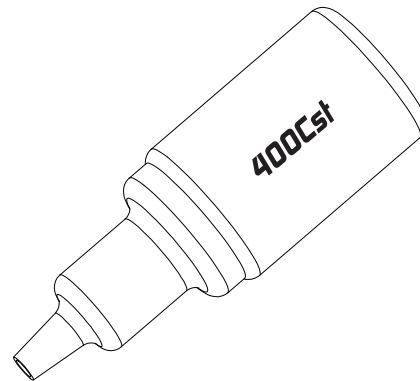

10.5mm

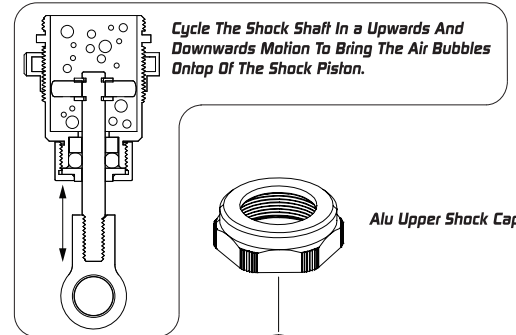

Cycle The Shock Shaft In a Upwards And Downwards Motion To Bring The Air Bubbles Ontop Of The Shock Piston.

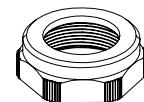

Alu Upper Shock Cap

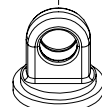

Shock Top Connector

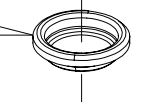

Shock Absorber Membrane

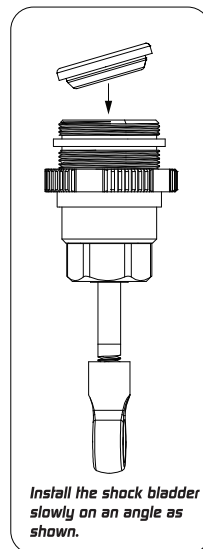

Install the shock bladder slowly on an angle as shown.

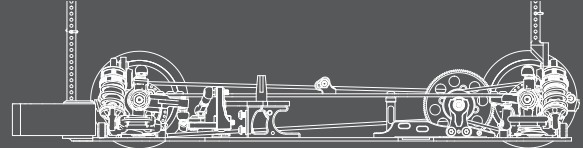

Bag Q,R

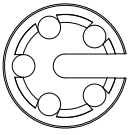

Spring Retainer
XP-10144



Pivot Ball 5.8 mm
XP-10121

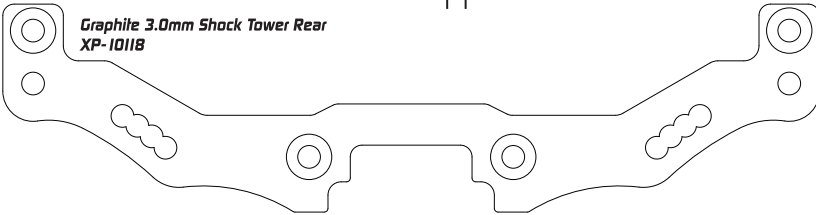

Graphite 3.0mm Shock Tower Rear
XP-10118

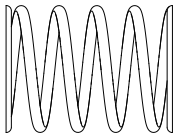

Shock Spring Medium Silver
XP-10169

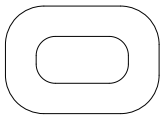

Body Height Adjuster Support
XP-10001

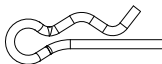

Body Clip
XP-10055



Flat Head Screw M3 x 8mm
XP-40048



Button Head Screw M3 x 6mm
XP-40037

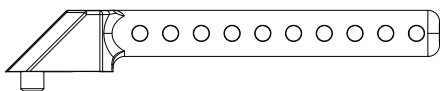

Rear Body Post
XP-10001



Alu Shim 3 x 6 x 1mm
XP-10119

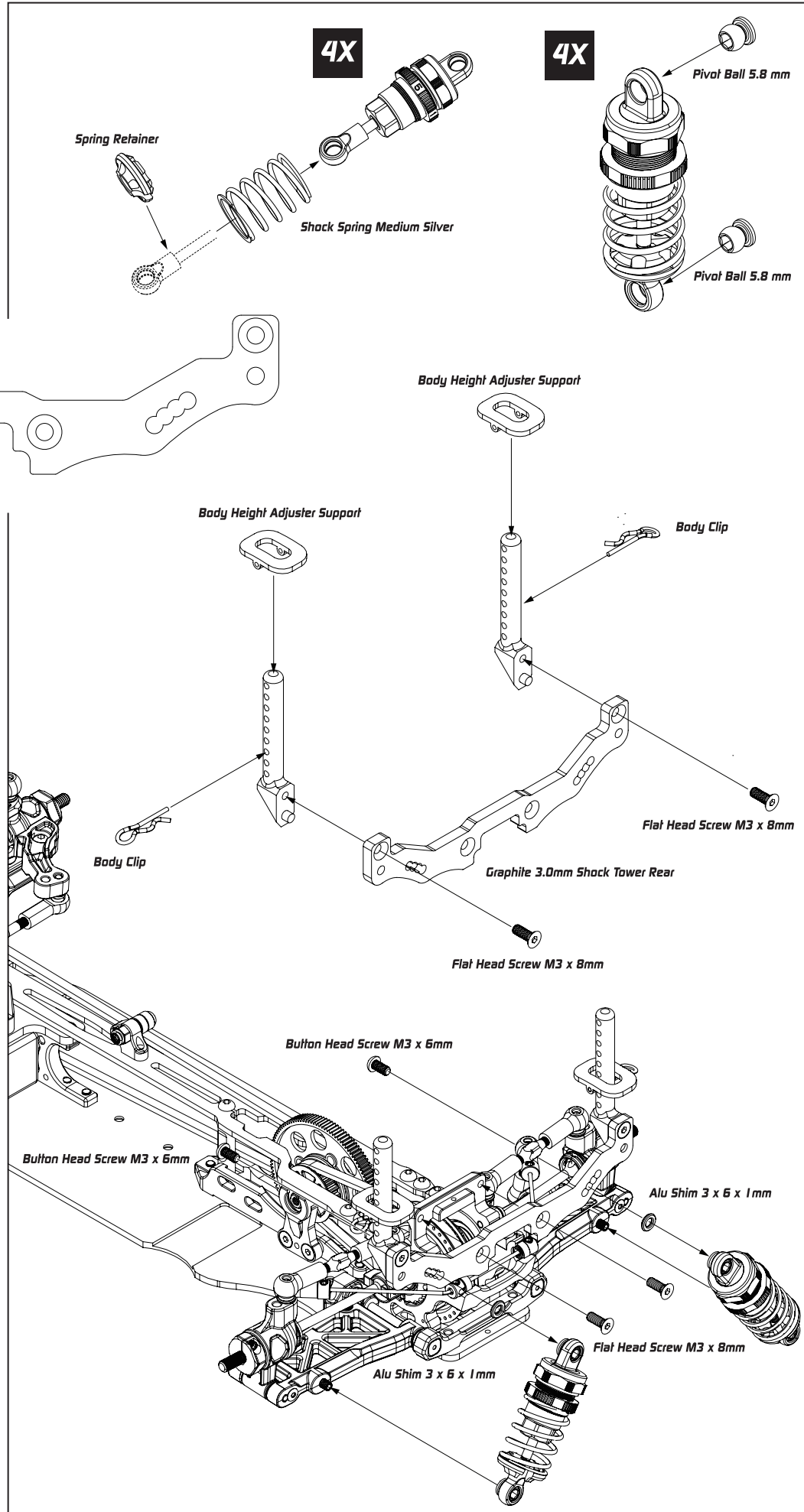

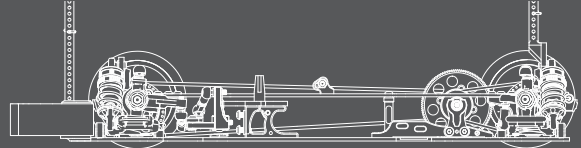

Bag Q,R

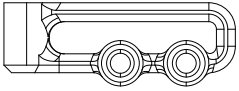

Composite Lipo Battery Backstop
XP-10180



Flat Head Screw M3 x 8mm
XP-40048



Flat Head Screw M3 x 6mm
XP-40046

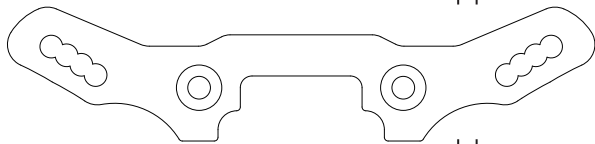

Graphite 3.0mm Shock Tower Front
XP-10106



Alu Shim 3 x 6 x 1mm
XP-10119



Bolt Head Screw M3 x 6mm
XP-40037

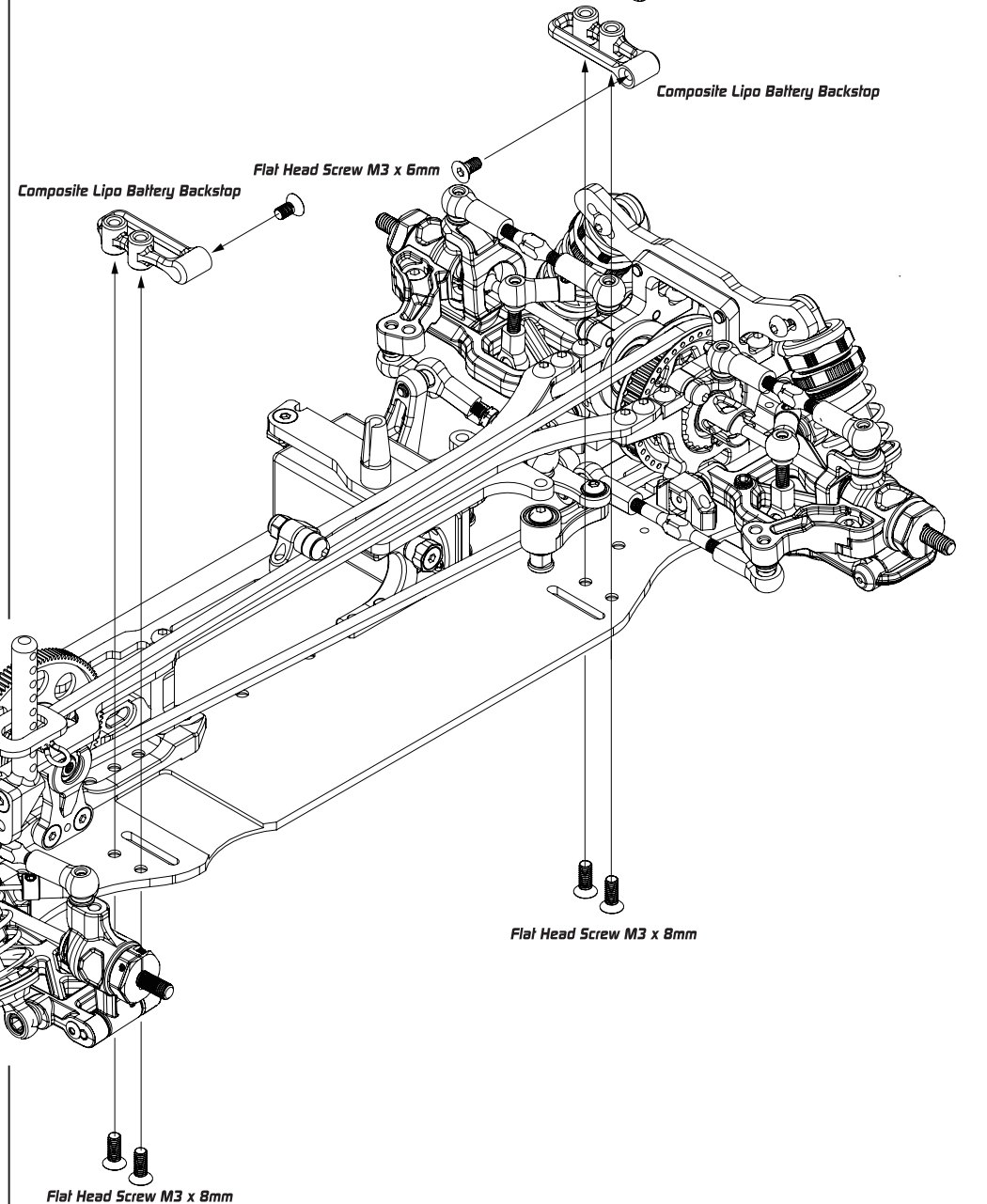
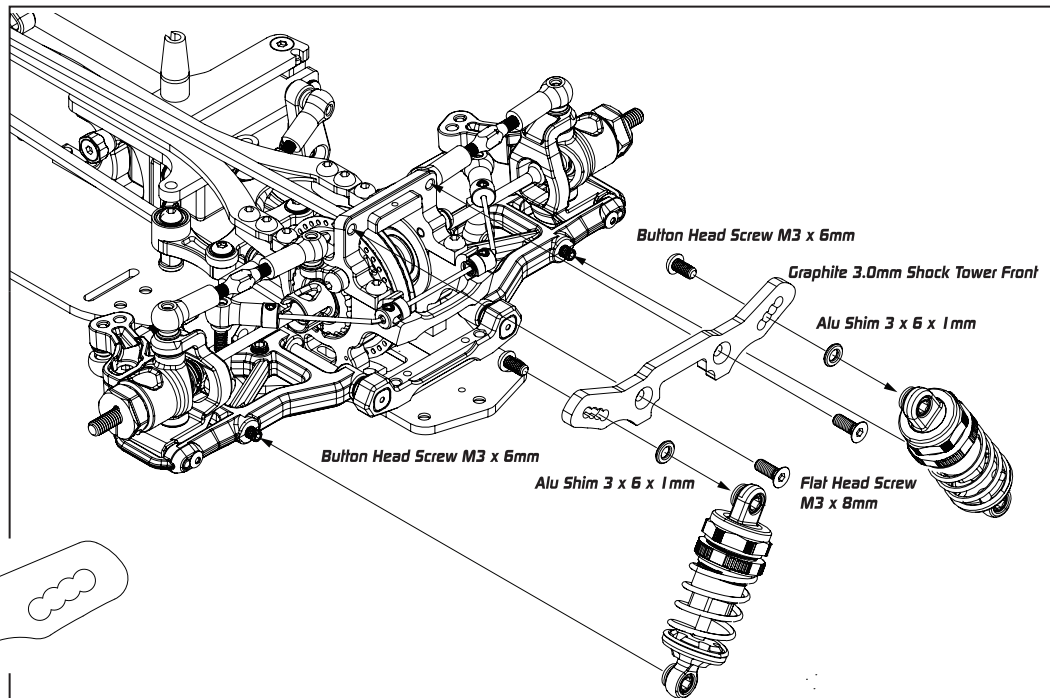

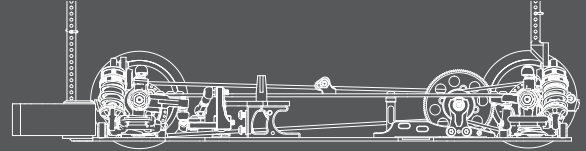

Bag R

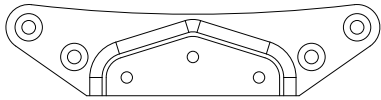

Lower Bumper
XP-10001

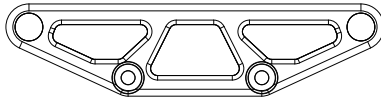

Bumper Plate
XP-10001

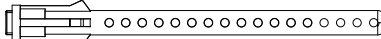

Front Body Post
XP-10001

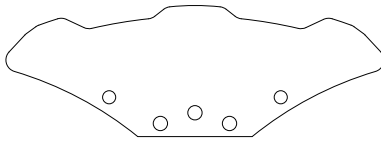

Foam Bumper
XP-10103

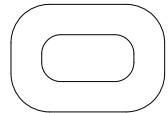

Body Height Adjuster Support
XP-10001

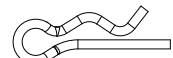

Body Clip
XP-10055



Flat Head Screw M3 x 10mm
XP-40049



Flat Head Screw M3 x 8mm
XP-40048

Flat Head Screw M3 x 10mm

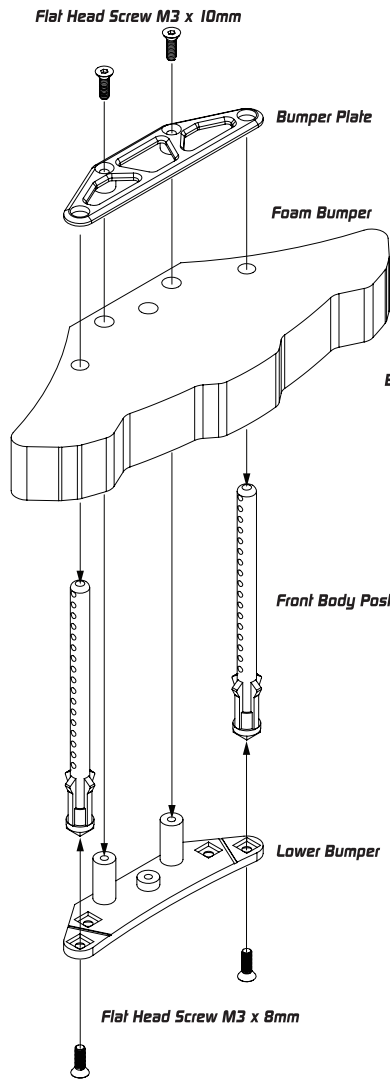

Body Height Adjuster Support

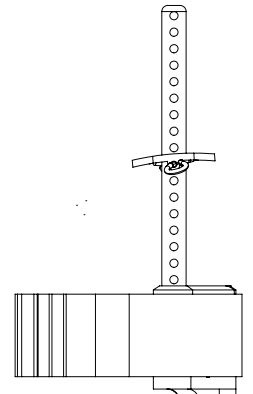
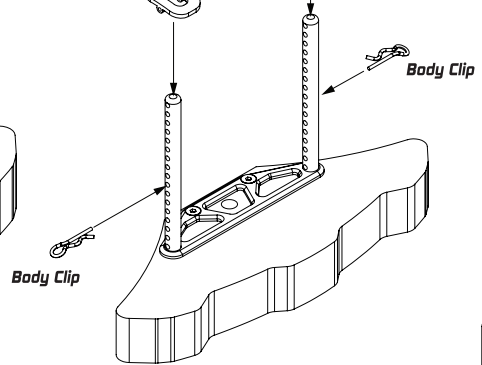

Flat Head Screw M3 x 8mm

Flat Head Screw M3 x 10mm

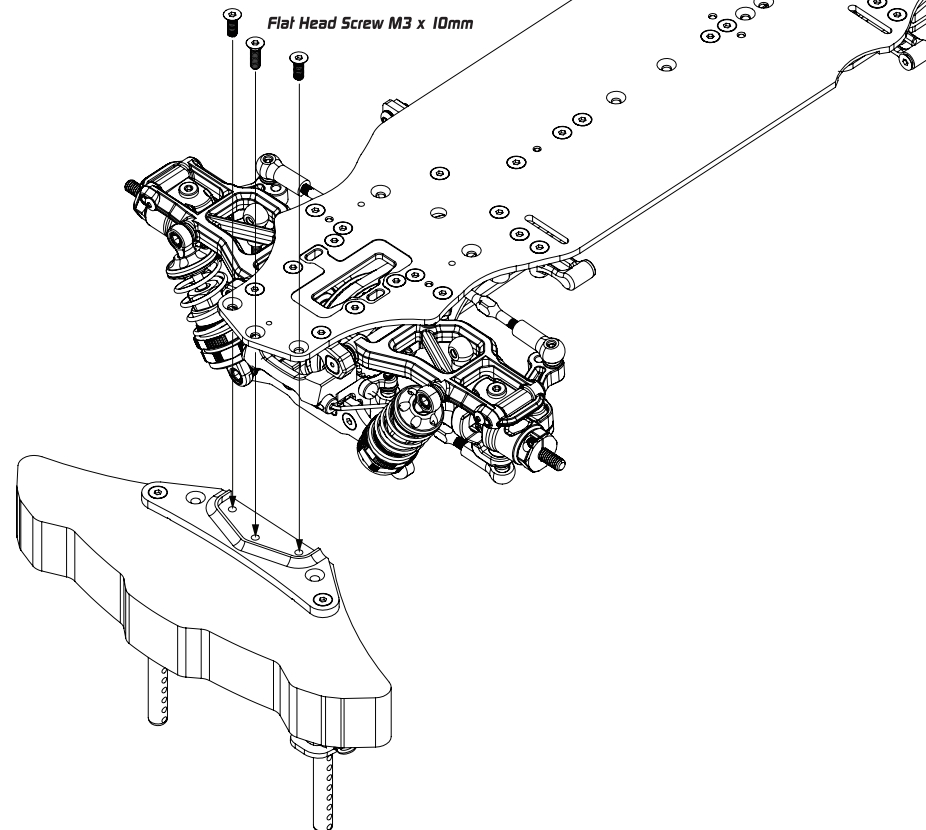

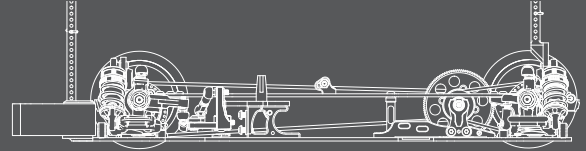

Bag L,N



Lock Nut 7mm
XP-40068

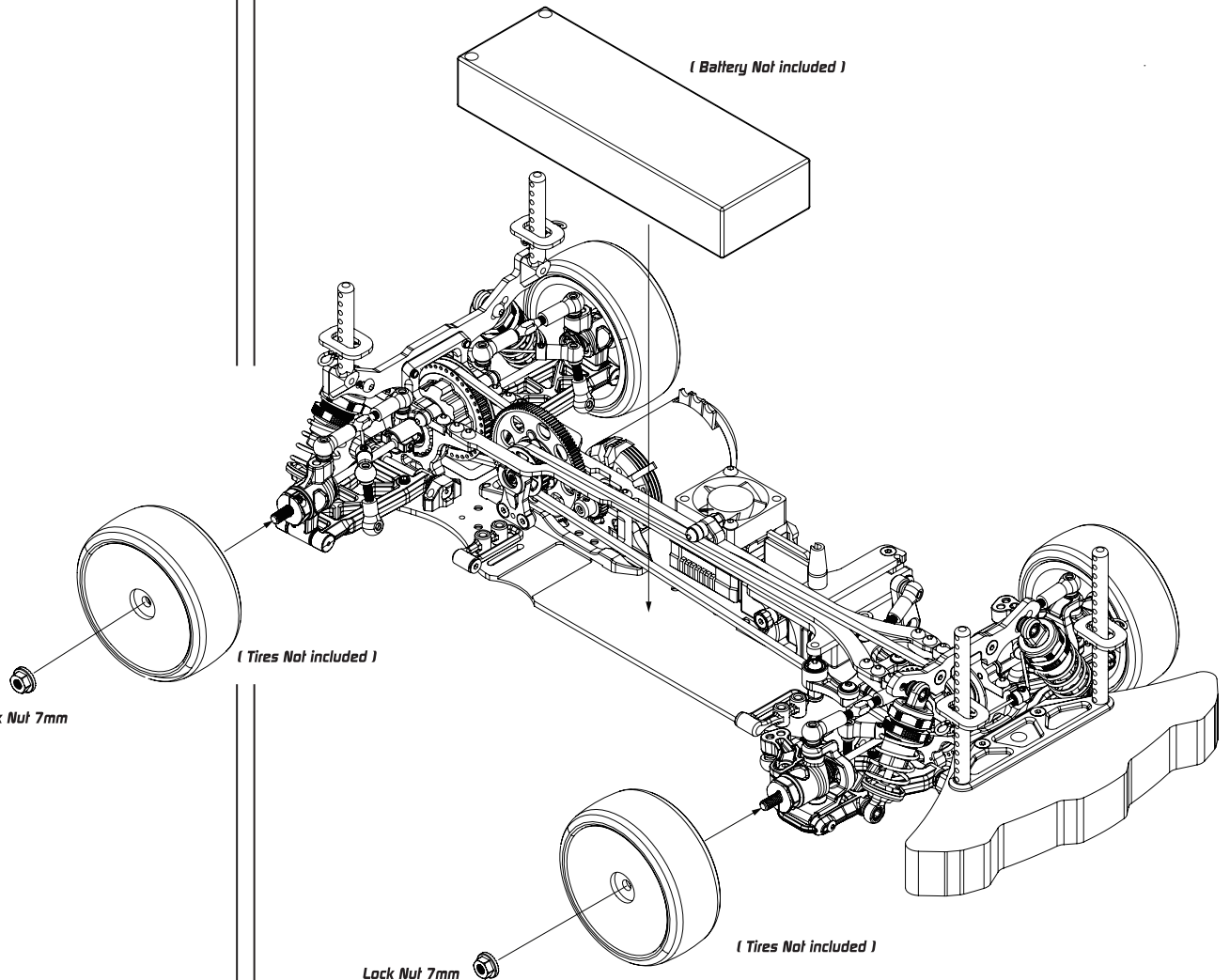
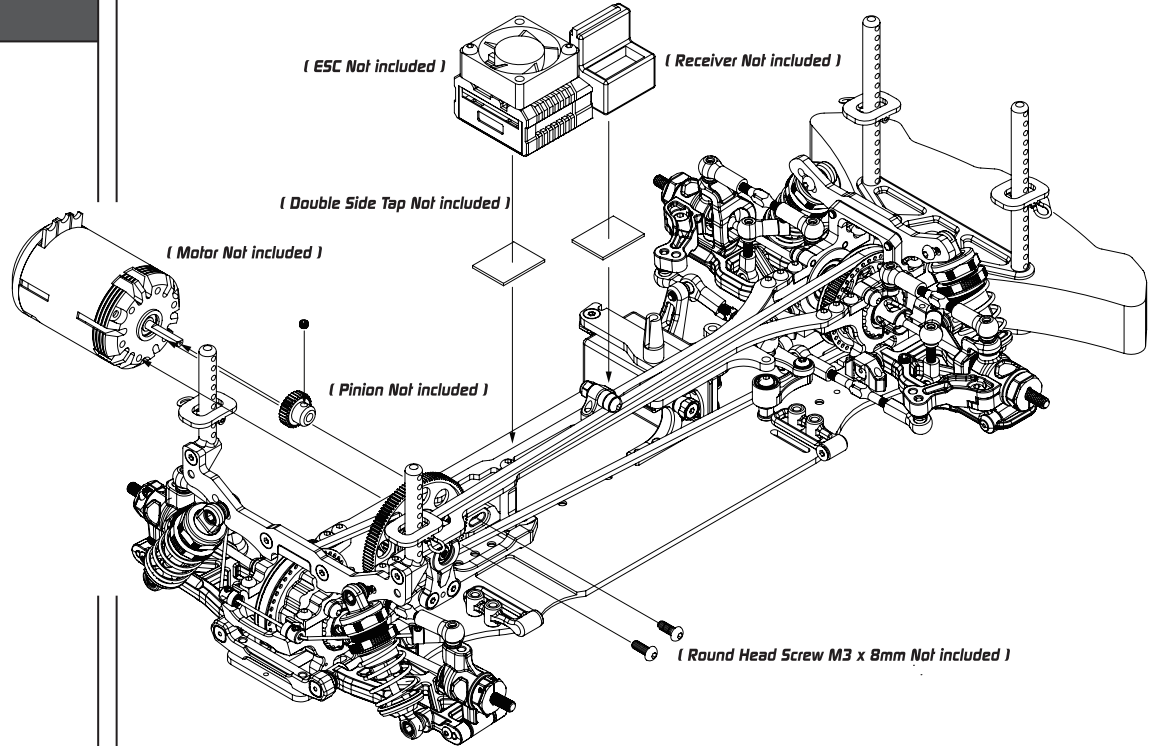

EXECUTE XQ1 Parts List

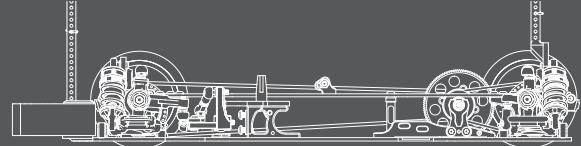

Model Number	Product Name
XP-10001	Bumper, Body Post & Antenna Holder for K1
XP-10002	4.8mm Ball End Set & Ball Bearing Hub for K1
XP-10008	Gear Differential Case and Cover
XP-10009	Gear Differential Bevel Satellite Gears Set
XP-10011	Gear Differential Re2PCS Parts
XP-10022	Gear Differential Set For Xray T4
XP-10052	KEVLAR DRIVE BELT REAR 3 x 189 MM
XP-10053	Spur Gear 64P 116T
XP-10055	Body Clips (20pcs)
XP-10101	XQ1 GRAPHITE 2.25MM BOTTOM CHASSIS PLATE
XP-10102	XQ1 GRAPHITE 2.0MM UPPER DECK
XP-10103	XQ1 FOAM BUMER
XP-10104	XQ1 ALUMINIUM FRONT 1 PIECE UPPER CLAMP
XP-10105	XQ1 FRONT CAMBERLINK MOUNT 2PCS
XP-10106	XQ1 GRAPHITE 3.0MM FRONT SHOCK TOWER
XP-10107	XQ1 COMPOSITE BALL BEARING TENSION ADJUSTMENT HUB 4PCS
XP-10108	XQ1 FRONT AND REAR COMPOSITE SUSPENSION ARM
XP-10109	XQ1 COMPOSITE STEERING BLOCK 2PCS
XP-10110	XQ1 COMPOSITE C HUB 4 degree DEG 2PCS
XP-10111	XQ1 ALUMINIUM DUAL SERVO SAVER ARM 2PCS
XP-10112	XQ1 ALUMINIUM STEERING POST FOR DUAL SERVO SAVER 2PCS
XP-10113	XQ1 ALUMINIUM STEERING PLATE FOR DUAL SERVO SAVER 4mm
XP-10114	XQ1 ALUMINIUM FF LOWER 1 PIECE SUSPENSION MOUNT
XP-10115	XQ1 ALUMINIUM LOWER BULKHEAD
XP-10116	XQ1 ALUMINIUM LAYSHAFT HOLDER BULKHEAD 2PCS
XP-10117	XQ1 ALUMINIUM MOTOR MOUNT
XP-10118	XQ1 GRAPHITE 3.0MM REAR SHOCK TOWER
XP-10119	XQ1 ALUMINIUM SHIM 3x6x1.0MM RED (20)
XP-10120	XQ1 ALUMINIUM SHIM 3x6x2.0MM RED (20)
XP-10121	XQ1 5.8 MM PIVOT BALL 8PCS
XP-10122	XQ1 COMPOSITE REAR UPRIGHT 2PCS
XP-10123	XQ1 ALUMINIUM 2 PIECE SUSPENSION MOUNT 2PCS
XP-10124	XQ1 ALUMINIUM RR LOWER 1 PIECE SUSPENSION MOUNT
XP-10125	XQ1 ALUMINIUM GEAR DIFF OUTDRIVE ADAPTER 2PCS
XP-10126	XQ1 STEEL SPOOL OUTDRIVE ADAPTER 2PCS
XP-10127	XQ1 ECCENTRIC BUSHING SET 4PCS
XP-10128	XQ1 DRIVESHAFT PROTECTOR BLADE 8PCS
XP-10129	XQ1 ALUMINIUM 5MM WHEEL HUB RED 2PCS
XP-10130	XQ1 REAR 1 PIECE UPPER CLAMP
XP-10131	XQ1 REAR CAMBERLINK MOUNT 2PCS
XP-10132	XQ1 KEVLAR FRONT DRIVE BELT 3 x 113 MM
XP-10133	XQ1 ALUMINIUM SOLID AXLE
XP-10134	XQ1 CENTER LAYSHAFT PULLEY
XP-10135	XQ1 Motor Mount Post
XP-10136	XQ1 ALUMINIUM SERVO MOUNT
XP-10137	XQ1 3.0MM GRAPHITE FLOATING SERVO HOLDER
XP-10138	XQ1 3.0MM GRAPHITE CHASSIS STIFFENER
XP-10139	XQ1 3.0MM SUSPENSION PIVOT PIN 4PCS
XP-10140	XQ1 2.3MM C HUB UPRIGHT PIVOT PIN 4PCS
XP-10141	XQ1 ALUMINIUM SHOCK SET 2PCS
XP-10142	XQ1 ALUMINIUM SHOCK BODY 2PCS
XP-10143	XQ1 SHOCK SHAFT 2PCS

Model Number	Product Name
XP-10144	XQ1 COMPOSITE SHOCK PARTS TREE
XP-10145	XQ1 ALUMINIUM LOWER SHOCK CAP 2PCS
XP-10146	XQ1 ALUMINIUM UPPER SHOCK CAP 2PCS
XP-10147	XQ1 SHOCK MEMBRANE 8PCS
XP-10148	XQ1 4.8MM BALL END 5MM THREAD 10PCS
XP-10149	XQ1 4.8MM BALL END 6MM THREAD 10PCS
XP-10150	XQ1 4.8MM BALL END 8MM THREAD 10PCS
XP-10151	XQ1 4.8MM BALL END 10MM THREAD 10PCS
XP-10152	XQ1 ALUMINIUM ANTI-ROLL BAR BUSHING (4+4)
XP-10153	XQ1 ALUMINIUM 2.0MM BOTTOM CHASSIS PLATE
XP-10154	XQ1 GRAPHITE 1.6MM UPPER DECK
XP-10155	XQ1 BALL BEARING ANTI-ROLL BAR SET 6PCS
XP-10156	XQ1 STEEL TURNBUCKLE 29 MM 4PCS
XP-10157	XQ1 STEEL STEERING TURNBUCKLE SET
XP-10158	XQ1 Composite Suspension Parts Set
XP-10159	XQ1 COMPOSITE 1.1MM PISTON SPACER SET
XP-10160	XQ1 SHOCK O-RING 8PCS
XP-10161	XQ1 ALUMINIUM SPRING TENSION ADJUST NUT 2PCS
XP-10162	XQ1 SILICONE O RING FOR SPRING ADJUST NUT 4PCS
XP-10163	XQ1 COMPOSITE SERVO HORN Belt TENSIONER SET
XP-10164	XQ1 C HUB KING PIN SET (2+2)
XP-10165	XQ1 UPRIGHT PIN SCREW 2X3.5MM 10PCS
XP-10166	XQ1 STEEL DOUBLE JOINT UNIVERSAL SHAFT 2PCS
XP-10167	XQ1 STEEL UNIVERSAL SHAFT REAR 2PCS
XP-10168	XQ1 Spring 2PCS Soft BK
XP-10169	XQ1 Spring 2PCS Medium SV
XP-10170	XQ1 Spring 2PCS Stiff PK
XP-10171	XQ1 PROGRESSIVE SHOCK SPRING SOFT 2PCS
XP-10172	XQ1 PROGRESSIVE SHOCK SPRING MEDIUM 2PCS
XP-10173	XQ1 PROGRESSIVE SHOCK SPRING STIFF 2PCS
XP-10174	XQ1 PROGRESSIVE SHOCK SPRING SET (6)
XP-10175	XQ1 ALUMINIUM SOLID LAYSHAFT
XP-10176	XQ1 ANTI-ROLL BAR 1.2MM (F/R)
XP-10177	XQ1 ANTI-ROLL BAR 1.3MM (F/R)
XP-10178	XQ1 ANTI-ROLL BAR 1.4MM (F/R)
XP-10179	DIFF GASKET 10PCS
XP-10180	COMPOSITE LIPO BATTERY STOPPER 2PCS
XP-10181	Gear Differential SPACER 5X15X0.4MM 10PCS
XP-10182	Gear Differential SPACER 3.6X9.5X0.2MM 10PCS
XP-10183	SILICONE Gear Differential O-RING 25x1mm 10PCS
XP-10184	SILICONE Gear Differential O-RING 5x2mm 10PCS
XP-10185	Battery Stopper and Layshaft Bearing Holder Parts Tree
XP-10186	XQ1 Brass Chassis Balancing Weights 8PCS
XP-10187	XQ1 Central Brass Chassis Balancing Weights 15g,25g
XP-10188	CAMBERLINK SHIM 0.5 1MM
XP-10189	MOTORMOUNT FLEX ADJUSTMENT PLATE
XP-10190	ALUMINIUMMINUM BLADE SPOOL CUP
XP-10191	RF ONE PIECE SUSPENSION MOUNT
XP-10192	ALUMINIUMMINUM ADJUSTABLE BATTERY STOPPERS
XP-10193	ALUMINIUMMINUM SPRING RETAINER
XP-10194	FR ONE PIECE SUSPENSION MOUNT

Either scan the QR code or head to: <http://www.rc-xpress.com/download> for the digital editable version setup sheet



Driver _____ Track Surface _____ Track Temperature _____
 Date _____ Track Traction _____ Result _____ Air Temperature _____
 Track _____ Country _____ Best Lap _____ Humidity _____ Remark _____

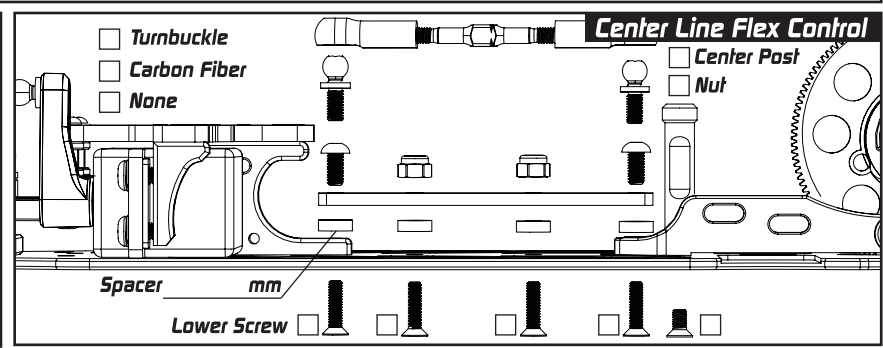
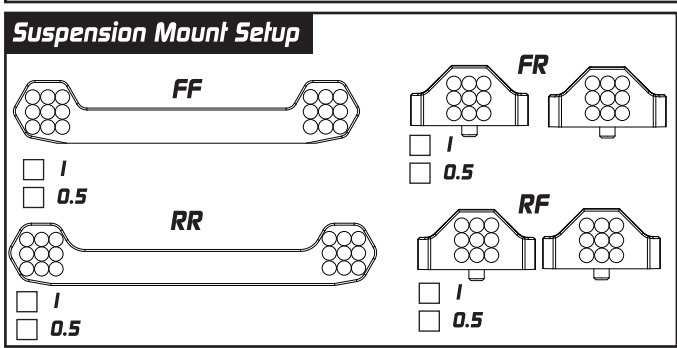
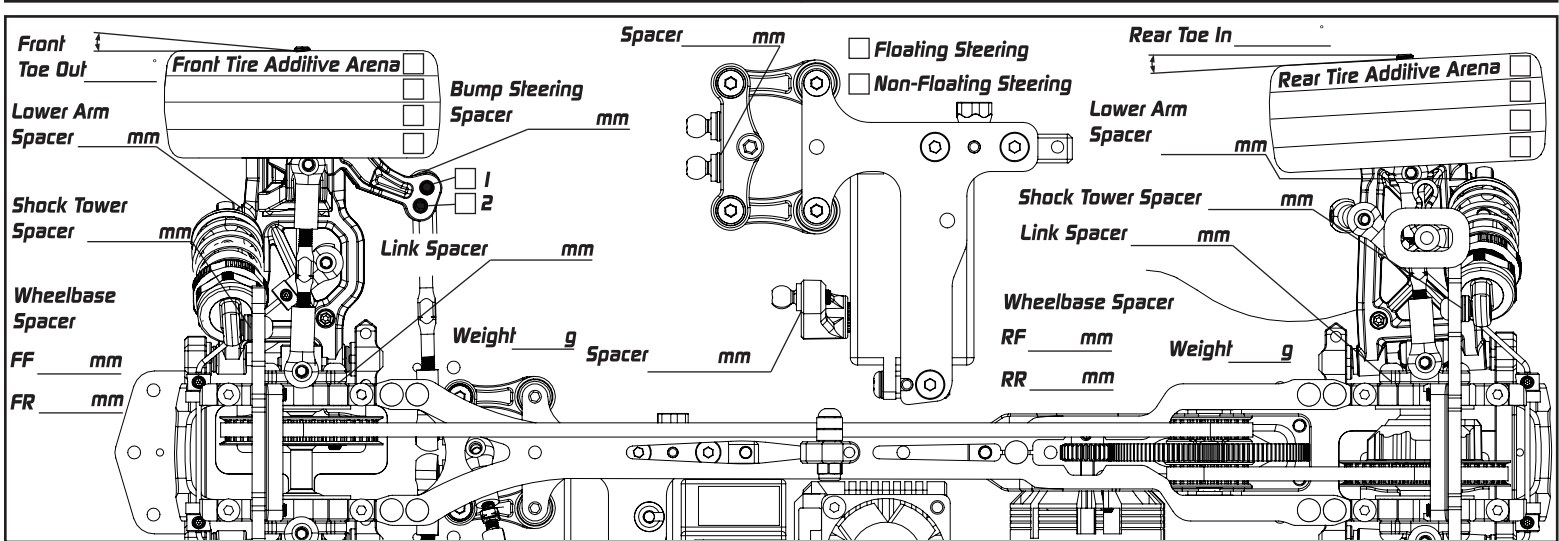
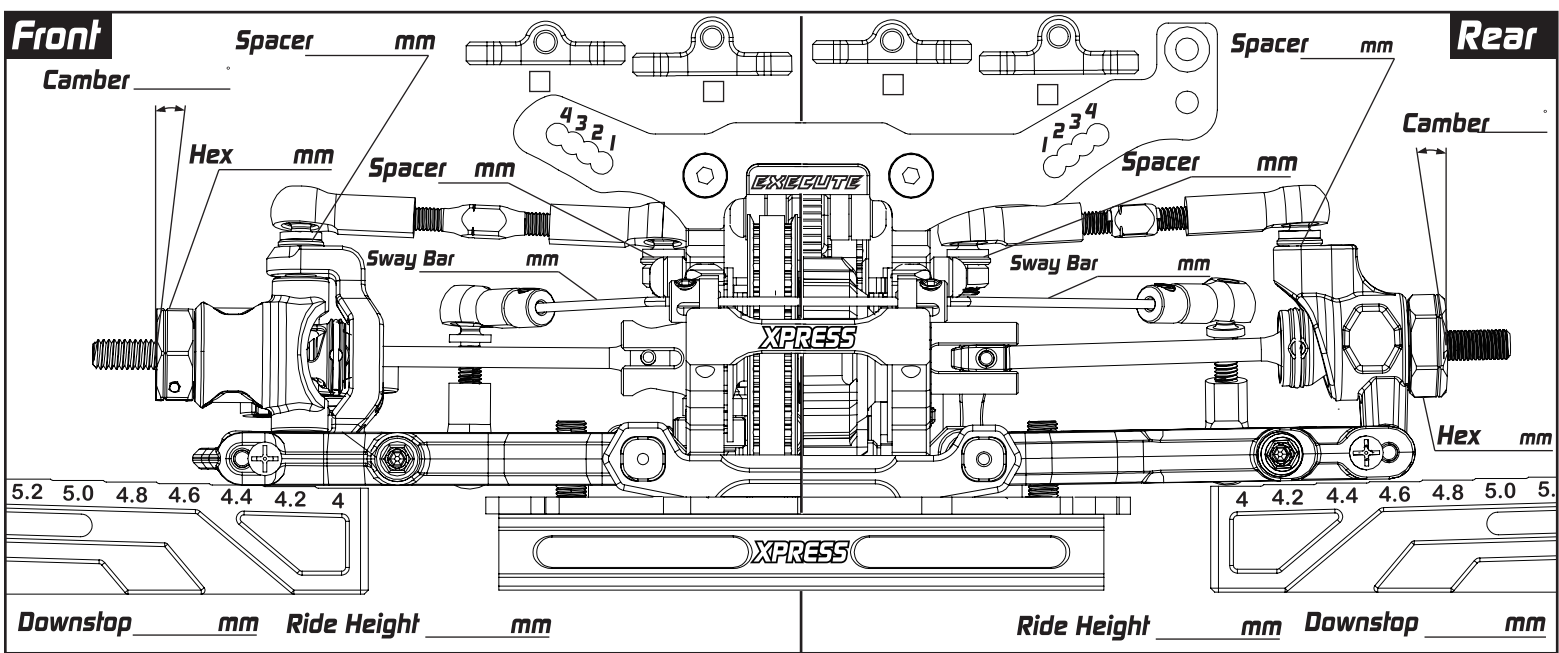

Damper Setup

	Front	Rear
Spring	_____	_____
Oil	_____	_____
Rebound	_____	_____
Piston	_____	_____
Length	_____	_____
Foam Insert	<input type="checkbox"/>	<input type="checkbox"/>
Hole In Cap	<input type="checkbox"/>	<input type="checkbox"/>

Transmission Setup

	Front	Rear
Oil	_____	_____
Weight	_____ g	_____ g
Position	_____	_____

Others

Servo _____ Tires _____
 Esc _____ Additive _____
 Motor _____ Body _____
 Spur _____ P/ _____ T Rear Wing _____
 Pinon _____ P/ _____ T FDR _____

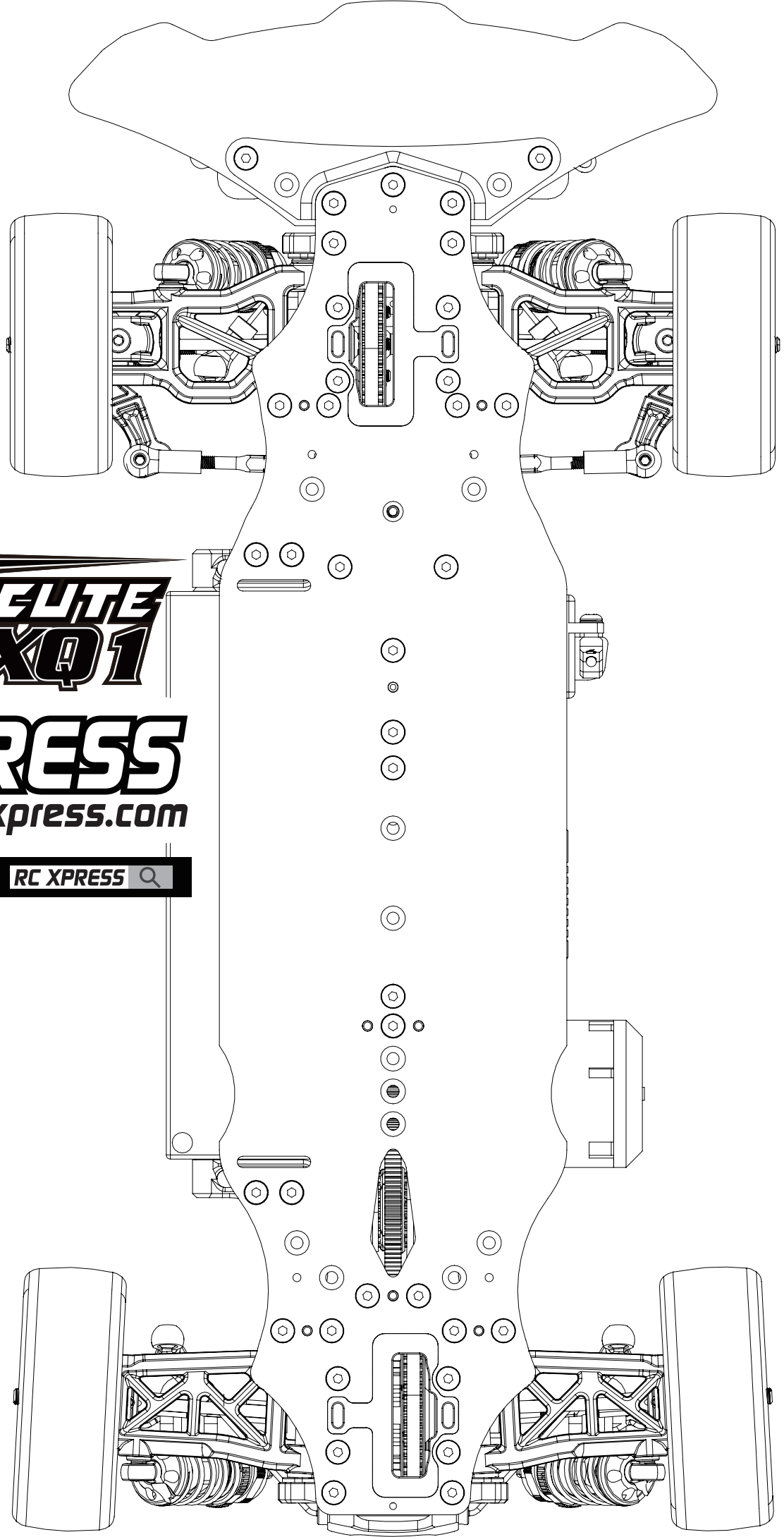

EXECUTE
1/10 COMPETITION TOURING CAR
XQ1

XPRESS
www.rc-xpress.com

